

HIWIN®

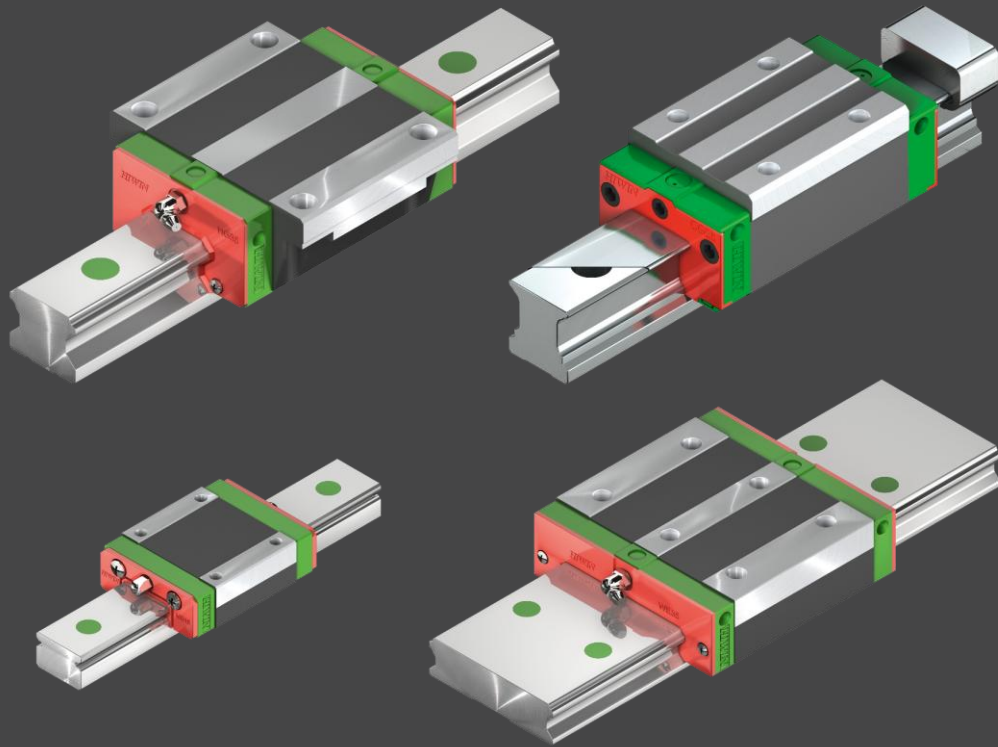

ASSEMBLY INSTRUCTIONS

Linear guideway

GW-06-0-EN-2604-MA

hiwin.de

Imprint

HIWIN GmbH

Brücklesbünd 1

77654 Offenburg

Germany

Fon +49 781 93278-0

info@hiwin.de

hiwin.de

All rights reserved.

Reprinting, even in part, is not permitted without our approval.

These assembly instructions are protected by copyright. Written permission is required from HIWIN GmbH for any duplication, publication in whole or in part, alterations or abridgement.

Contents

1	General	5
1.1	About these assembly instructions	5
1.2	Presentation and layout conventions used in these assembly instructions	5
1.3	Warranty and liability	7
1.4	Manufacturer information	7
1.5	Product monitoring	7
2	Basic safety information	8
2.1	Proper use	8
2.2	Exclusion of liability in the event of alteration and improper handling	8
2.3	Qualified personnel	8
3	Product description	9
3.1	Order code of the linear guideways	9
3.2	Setup and operation of the linear guideway	11
3.3	Tolerances depending on the accuracy class	11
3.4	Parallelism	12
3.5	Accuracy – height and width	13
4	Transport and setup	15
4.1	Delivery condition	15
4.2	Scope of delivery	15
4.3	Transport to the installation location	15
4.4	Storage	16
5	Assembly	17
5.1	Preliminary work	17
5.2	Profile rails	17
5.3	Covering the mounting holes	23
5.4	Block	39
5.5	Tightening torques of the mounting bolts	41
6	Commissioning	42
7	Maintenance and cleaning	42
7.1	Cleaning	42
8	Lubrication	43
8.1	Basic information on lubrication	43
8.2	Safety	43
8.3	Lubrication connectors	44
8.4	Use of central lubrication systems	49
8.5	Lubricating pressure	50
8.6	Selecting a lubricant	50
8.7	HIWIN greases	53
8.8	Miscibility of lubricants	53
8.9	Grease guns and lubrication adapters	54
8.10	Standard lubrication condition of the linear guideways on delivery	55
8.11	Initial lubrication during commissioning	56
8.12	Changing lubricant	57
8.13	Lubricant quantities	57
8.14	Relubrication	58

9	Disposal	61
10	Troubleshooting measures	61
11	Accessories	62
11.1	Long-term lubrication unit	62
11.2	Additional assembly and disassembly tool	65
12	Appendix	66
12.1	Maximum speeds and accelerations for HIWIN linear guideways	66
12.2	Assembly tolerances	66
12.3	Technical data of block	75
12.4	Technical data of profile rails	91

1 General

1.1 About these assembly instructions

These assembly instructions are intended for planners, developers and operators of systems who plan and install the named products as machine elements. It is also addressed to all persons who carry out the following work:

- Transport
- Assembly
- Retrofitting or upgrading
- Setup
- Commissioning
- Operation
- Cleaning
- Maintenance
- Troubleshooting
- Decommissioning, disassembly and disposal

1.1.1 Requirements

We assume that

- The operating personnel have been instructed in the safe operation of the HIWIN linear guideways and have read and understood these assembly instructions in full
- Maintenance personnel maintain and repair the HIWIN linear guideways in such a way that they present no danger to persons, the environment or property

1.1.2 Availability

The assembly instructions must always be available to all persons working with or on the named products. The assembly instructions are also available at hiwin.de.

1.2 Presentation and layout conventions used in these assembly instructions

1.2.1 Instructions for actions

Instructions for actions are provided in sequential order and identified with a triangle symbol. The results of the actions are accompanied by an arrow.

Example:

- Instruction 1
- Instruction 2
- ✓ Result

1.2.2 Lists

Lists are identified through the use of bullet points.

Example:

Lubricants

- Reduce wear and tear
- Protect from dirt
- ...

1.2.3 Presentation of safety information

Safety notices are always indicated by a signal word and sometimes with a hazard-specific symbol (see section [1.2.4 Symbols used](#)).

The following signal words/hazard levels are used:

 **Danger!** Immediate danger!

 Failure to follow this safety instruction will result in severe or fatal injury!

 **Warning!** Potentially dangerous situation!

 Failure to follow this safety instruction could result in severe or fatal injury!

 **Attention!** Potentially dangerous situation!





 Failure to follow this safety instruction could result in moderately severe or minor injury!

 **Caution!** Potentially dangerous situation!

 Failure to follow this safety instruction could result in damage to property or the environment!

1.2.4 Symbols used

The following symbols are used in these assembly instructions and on the product:

Warning symbols			
	Warning of crushing risk!		Warning of dangerous electrical voltage!
	Warning of danger from suspended loads!		Environmentally hazardous substance!
	Warning of cuts!		

1.2.5 Information

Note:

Provides general information and recommendations.

1.3 Warranty and liability

The manufacturer's "General Terms and Conditions of Sale and Delivery" apply.

1.4 Manufacturer information

Address	HIWIN GmbH Brücklesbünd 1 77654 Offenburg, Germany
Telephone	+49 (0) 781 / 9 32 78 - 0
Technical customer service team	+49 (0) 781 / 9 32 78 - 77
Fax	+49 (0) 781 / 9 32 78 - 90
Technical customer service team fax	+49 (0) 781 / 9 32 78 - 97
E-mail	support@hiwin.de
Internet	hiwin.de

1.5 Product monitoring

Please inform HIWIN, as manufacturer of the named products, about:

- Accidents
- Potential risks involving the torque motors
- Any unclear information in these assembly instructions

2 Basic safety information

⚠ Warning! Failure to comply with the following notices could be dangerous!

This chapter is for the safety of everyone who works with, assembles, installs, operates, maintains or disassembles the linear guideways.

▶ Follow the instructions below!

2.1 Proper use

The linear guideway is a linear guide element that is used to guide a linear movement within a machine or an automated system.

The linear guideways are designed for installation and operation in horizontal and vertical position. In the event of vertical mounting, a suitable clamping or braking device must be provided to be able to prevent unintentional lowering of the load. The linear guideways may only be used as described for the intended purpose.

2.2 Exclusion of liability in the event of alteration and improper handling

No changes whatsoever may be made to the linear guideways that are not described in these assembly instructions. If a modified design is necessary, please contact the manufacturer.

The manufacturer accepts no liability in the event of modifications or improper assembly, installation, commissioning, operation, maintenance or repair.

Only original HIWIN parts are permitted as spare parts and accessories. Spare parts and accessories not supplied by HIWIN have not been tested for operation with HIWIN linear guideways and may impair operational safety. The manufacturer accepts no liability for damage caused by the use of non-approved spare parts and accessories.

2.3 Qualified personnel

The linear guideway may only be installed, integrated into higher-level systems, commissioned, operated and maintained by competent personnel. A qualified person is one who

- Has suitable technical training
- and**
- Has been instructed by the machine operator in operation and the valid safety guidelines and can assess the dangers to be expected
- and**
- Has read through these assembly instructions in full and understood them
- and**
- Has access to the assembly instructions at all times

3 Product description

3.1 Order code of the linear guideways

3.1.1 Order number of block (not assembled)

Number	1	2	3	4	5	6	7	8	9
Order code	HG	W	25	C	C	Z0	H	ZZ	E2
1	HG	Series							
2	W	Type: W: Flange block H: High square block L: Low square block							
3	25	Size							
4	C	Load type: S: Medium load C: Heavy load H: Super heavy load							
5	C	Block fastening: A: From above C: From above or below							
6	Z0	Preload ID: Z0, ZA, ZB							
7	H	Accuracy class: C, H, P, SP, UP							
8	ZZ	Dust protection: None: Standard (SS) SSL, ZZ, ZZX, DD, KK, KXX, SW, ZW, ZWX							
9	E2	None: Standard E2: Long-term lubrication unit							

3.1.2 Order number of profile rail (not assembled)

Number	1	2	3	4	5	6
Order code	HG	R	25	R	1200	H
1	HG	Series				
2	R	Profile rail				
3	25	Size				
4	R	Rail mounting: R: From above T: From below				
5	1,200	Length of rail [mm]				
6	H	Accuracy class: C, H, P, SP				

3.1.3 Order code for linear guideway (assembled)

Number	1	2	3	4	5	6	7
Order code	HG	W	25	C	C	2	R
1	HG	Series					
2	W	Type: W: Flange block H: High square block L: Low square block					
3	25	Size					
4	C	Load type: S: Medium load C: Heavy load H: Super heavy load					
5	C	Block fastening: A: From above C: From above or below					
6	2	Number of blocks per profile rail					
7	R	Rail mounting: R: From above T: From below					

3.1.4 Order code for linear guideway (assembled) – continued

Number	8	9	10	11	12	13
Continuation order code	1600	Z0	H	2	DD	E2
8	1,600	Length of rail [mm]				
9	Z0	Preload ID: Z0, ZA, ZB				
10	H	Accuracy class: H, P, SP, UP				
11	2	Rails per axis ¹⁾				
12	DD	Dust protection: None: Standard (SS) SSL, ZZ, ZZX, DD, KK, KXX, SW, ZW, ZWX				
13	E2	None: Standard E2: Long-term lubrication unit SE: Steel end cap				

¹⁾ The number 2 is also a quantity indication, i.e. one piece of the article described above consists of one pair of rails. No number is given for single profile rails. In the case of multi-part rails, the joint is offset as standard.

3.2 Setup and operation of the linear guideway

A linear guideway makes it possible to move in a linear motion with rolling elements. The use of balls and rollers between the rail and block in a linear guideway makes precise linear movements possible. Compared with a standard sliding guide, the friction coefficient here is just one fiftieth. The high efficiency and zero backlash mean that the HIWIN linear guideway can be used in various ways.

The following illustration shows the structure and the installed components.

Fig. 3.1: Exploded view of the construction of a linear guideway

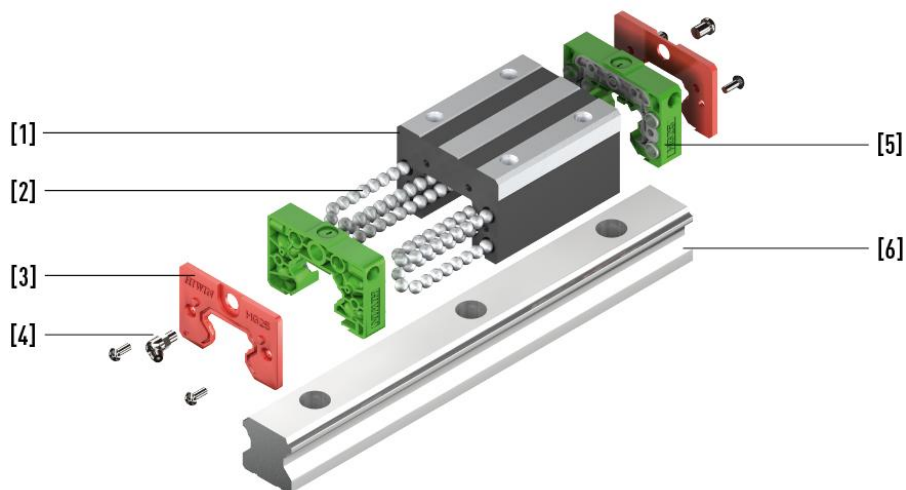

1	Basic unit	4	Grease nipple
2	Rolling element	5	Recirculation system
3	Wiper	6	Profile rail

3.3 Tolerances depending on the accuracy class

Linear guideways are available in various accuracy classes according to the parallelism between block and rail, height accuracy H and width accuracy N.

Five accuracy classes are available for the **HG, QH, EG, QE, CG, WE, QW, UR, RG, CRG** and **QR** series, and three for the **MG** series.

Fig. 3.2: Tolerances for HIWIN linear guideways

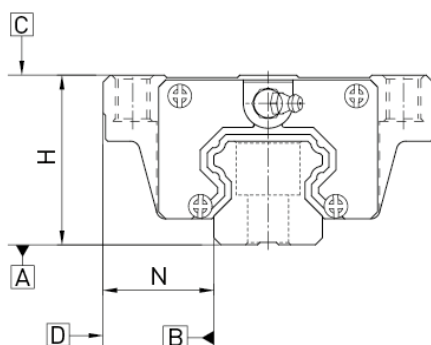

3.4 Parallelism

Parallelism of locating surfaces D and B of the block and rail and of top block surface C to mounting surface A of the rail. Ideal installation of the linear guideway and the measurement in the centre of the block are prerequisites.

Table 3.1: Tolerance of parallelism between block and profile rail – HG, QH, EG, QE, CG, WE, QW, UR, RG, CRG and QR series

Rail length [mm]	Accuracy class				
	C	H	P	SP	UP
- 100	12	7	3	2	2
100 – 200	14	9	4	2	2
200 – 300	15	10	5	3	2
300 – 500	17	12	6	3	2
500 – 700	20	13	7	4	2
700 – 900	22	15	8	5	3
900 – 1.100	24	16	9	6	3
1.100 – 1.500	26	18	11	7	4
1.500 – 1.900	28	20	13	8	4
1.900 – 2.500	31	22	15	10	5
2.500 – 3.100	33	25	18	11	6
3.100 – 3.600	36	27	20	14	7
3.600 – 4.000	37	28	21	15	7

Unit: µm

Table 3.2: Tolerance of parallelism between block and profile rail – MG series

Rail length [mm]	Accuracy class		
	C	H	P
- 50	12	6	2.0
50 – 80	13	7	3.0
80 – 125	14	8	3.5
125 – 200	15	9	4.0
200 – 250	16	10	5.0
250 – 315	17	11	5.0
315 – 400	18	11	6.0
400 – 500	19	12	6.0
500 – 630	20	13	7.0
630 – 800	22	14	8.0
800 – 1.000	23	16	9.0
1.000 – 1.200	25	18	11.0
1.200 – 1.300	25	18	11.0
1.300 – 1.400	26	19	12.0

Rail length [mm]	Accuracy class		
	C	H	P
1.400 – 1.500	27	19	12.0
1.500 – 1.600	28	20	13.0
1.600 – 1.700	29	20	14.0
1.700 – 1.800	30	21	14.0
1.800 – 1.900	30	21	15.0
1.900 – 2.000	31	22	15.0

Unit: µm

3.5 Accuracy – height and width

Height tolerance of H: Permissible absolute dimension deviation of height H, measured between the centre of bolting surface C and rail underside A, with any position of the block on the rail.

Height variance of H: Permissible deviation of height H between several blocks on one rail, measured at the same position of the rail.

Width tolerance of N: Permissible absolute dimension deviation of width N, measured between the centre of bolting surfaces D and B, with any position of the block on the rail.

Width variance of N: Permissible deviation of width N between several blocks on one rail, measured at the same position of the rail.

Table 3.3: Tolerances of height and width – HG, QH, EG, QE, CG, WE, QW, UR, RG, CRG and QR series

Size	Accuracy class	Height tolerance of H (T _H)	Width tolerance of N	Height variance of H	Width variance of N
15, 17, 20, 21	C (Normal)	±0.1	±0.1	0.02	0.02
	H (high)	±0.03	±0.03	0.01	0.01
	P (precision)	0/-0.03 ¹⁾ ±0.015 ²⁾	0/-0.03 ¹⁾ ±0.015 ²⁾	0.006	0.006
	SP (super precision)	0/-0.015	0/-0.015	0.004	0.004
	UP (ultra precision)	0/-0.008	0/-0.008	0.003	0.003
25, 27, 30, 35	C (Normal)	±0.1	±0.1	0.02	0.03
	H (high)	±0.04	±0.04	0.015	0.015
	P (precision)	0/-0.04 ¹⁾ ±0.02 ²⁾	0/-0.04 ¹⁾ ±0.02 ²⁾	0.007	0.007
	SP (super precision)	0/-0.02	0/-0.02	0.005	0.005
	UP (ultra precision)	0/-0.01	0/-0.01	0.003	0.003

Size	Accuracy class	Height tolerance of H (T _H)	Width tolerance of N	Height variance of H	Width variance of N
45, 50, 55	C (Normal)	±0.1	±0.1	0.03	0.03
	H (high)	±0.05	±0.05	0.015	0.02
	P (precision)	0/-0.05 ¹⁾ ±0.025 ²⁾	0/-0.05 ¹⁾ ±0.025 ²⁾	0.007	0.01
	SP (super precision)	0/-0.03	0/-0.03	0.005	0.007
	UP (ultra precision)	0/-0.02	0/-0.02	0.003	0.005
65	C (Normal)	±0.1	±0.1	0.03	0.03
	H (high)	±0.07	±0.07	0.02	0.025
	P (precision)	0/-0.07 ¹⁾ ±0.035 ²⁾	0/-0.07 ¹⁾ ±0.035 ²⁾	0.01	0.015
	SP (super precision)	0/-0.05	0/-0.05	0.007	0.01
	UP (ultra precision)	0/-0.03	0/-0.03	0.005	0.007

Unit: mm

¹⁾ Assembled linear guideway

²⁾ Unassembled linear guideway

Table 3.4: Tolerances of height and width – MG series

Size	Accuracy class	Height tolerance of H	Width tolerance of N	Height variance of H	Width variance of N
02, 03, 05, 07, 09, 12, 15	C (Normal)	± 0.04	± 0.040	0.030	0.03
	H (high)	± 0.02	± 0.025	0.015	0.02
	P (precision)	± 0.01	± 0.015	0.007	0.01

Unit: mm

4 Transport and setup

4.1 Delivery condition

The following delivery states are possible for linear guideways:

- **Mounted:** Blocks are already mounted on the rail, the block is secured to the profile rail with the transport securing device.
- **Not mounted:** Block and rail are supplied separately.

4.2 Scope of delivery

The scope of delivery varies depending on the model, accessories and options ordered.

4.3 Transport to the installation location

 **Warning!** Danger from suspended loads or falling parts!

Lifting heavy loads can cause damage to health!

- ▶ Assembly and maintenance of the linear guideways only by qualified personnel!
- ▶ Take the mass of the parts into account during transport. Use suitable lifting gear!
- ▶ Comply with the applicable industrial safety regulations for handling suspended loads.
- ▶ Secure linear guideways against tipping before transport!

 **Attention!** Risk of impact and crushing!

If the transport securing device is missing, the block can move uncontrollably on the profile rail and cause injuries.

- ▶ Do not remove the transport securing device until assembly!

 **Caution!** Danger of property damage!

Deflection during transport impairs the function and accuracy of the linear guideways.

- ▶ Support long linear guideways at several points during transport!

Note

The linear guideways are precision products and must be handled with care. Shocks and impacts can damage the linear guideways. Reduced accuracy and service life can be the result. Transport the product packed as close as possible to the installation site. Only remove the packaging once there.

4.3.1 Environmental conditions

Ambient temperature:	+5 °C to +40 °C
Installation site:	Level, dry, vibration-free
Atmosphere:	Non-corrosive, non-explosive

Safety equipment to be provided by the operator

Possible safety equipment/measures:

- Personal protective equipment according to UVV
- Electrosensitive protective equipment
- Mechanical safety equipment

4.4 Storage

- Always store linear guideways in the transport packaging so they are protected from impacts.
- The storage room must be dry, frost-free and free of corrosive atmosphere.
- Clean and protect used linear guideways before storage.

5 Assembly

⚠ Warning! Risk of injury!

There is an increased risk of injury during assembly.

- ▶ During assembly and disassembly, transport the linear guideway horizontally. If this is not possible, prevent the mounted blocks from running off the profile rail by attaching a suitable holding device!
- ▶ For large or long linear guideways, use lifting gear for assembly if necessary!

⚠ Attention! Risk of damage to health and the environment!

Contact with lubricants can cause irritation, poisoning and allergic reactions as well as damage to the environment.

- ▶ Only use suitable substances that are safe for humans. Observe the manufacturer's safety data sheets.
- ▶ Dispose of substances appropriately.

5.1 Preliminary work

- Do not remove the transport packaging until immediately before assembly to avoid damage.
- Do not remove the transport securing device of the block on the rail until immediately before mounting the rail.
- After removing the transport securing device, keep the profile rail as horizontal as possible to prevent the blocks from running off the profile rail in an uncontrolled manner.
- If you have ordered a one-piece profile rail from the CG series with a cover strip, disassemble the cover strip first in accordance with section [5.3.4](#).
- Avoid getting the profile rail dirty during installation. Chippings and other items must be removed. All cleaning information can be found in section [7.1](#).

5.2 Profile rails

The installation position of the profile rails depends on the requirements of the machine and the load direction. The accuracy of the profile rail is determined by how straight and level the contact surfaces are because the profile rail is pressed against them when the screws are tightened. Profile rails that are not pressed against a contact surface may have greater tolerances in terms of straightness.

⚠ Caution! Damage caused by tension on the linear guideway!

Linear guideways are extremely precise guides. Tension due to incorrect installation can result in premature failure of the linear guideways.

- ▶ The assembly instructions described in chapter [5](#) must be observed!

Note

Please observe the assembly tolerances in section [12.2](#).

5.2.1 Labelling of the linear guideways

The reference edge of the profile rail is marked by arrows on the top of the rail. For very short rail sections, the reference side is labelled on the front side of the rail with an arrow.

Fig. 5.1: Labelling of reference side of a profile rail

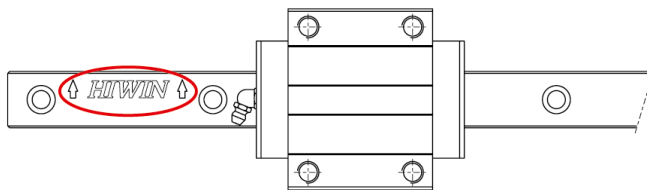
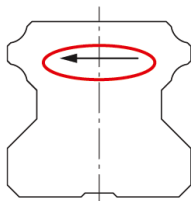

Fig. 5.2: Labelling of reference side for short profile rails and for the PG series



5.2.2 Different types of linear guideways

R-rails are assembled using mounting bolts from above; T-rails are assembled using mounting bolts from below. The information below describes the process of assembling the R-rail; the T-rail is assembled in the same way.

Fig. 5.3: T-rail



Fig. 5.4: R-rail



5.2.3 Cleaning the mounting surface

- Remove all dirt from the mounting surface
- Holes and reference edge must be burr-free; remove burrs with an oil stone if necessary [1].

Fig. 5.5: Cleaning the mounting surface

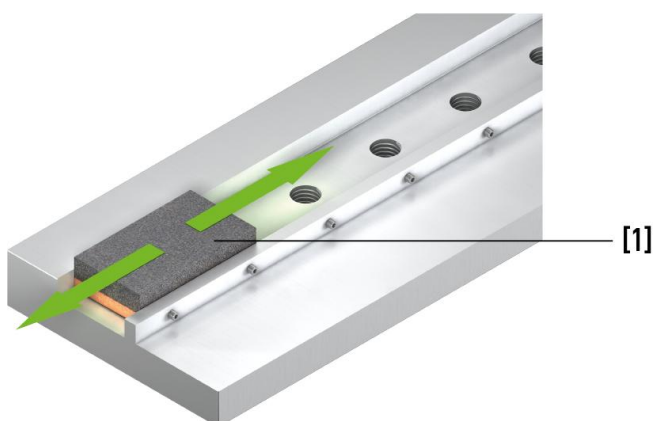

5.2.4 Mounting the profile rail on a reference edge

A. Attaching the profile rail

- Place the reference side of the profile rail (see section [5.2.1](#)) against the reference edge of the machine bed.
- Loosely attach the mounting bolts.

Fig. 5.6: Placing the profile rail on the reference edge

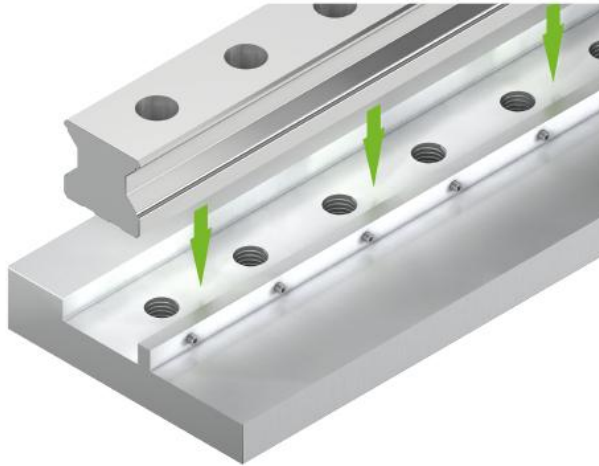

B. Tensioning the profile rail with the machine bed

Note

Maintain the permissible tolerances for the mounting areas and mounting deviations of the relevant series in accordance with section [3.3](#), [3.4](#), and [3.5](#)

Note

The profile rails can be tensioned using a terminal block or vices.

Tensioning of the profile rail using a terminal block:

- Tighten the allen set screws on the terminal block in order to press the profile rail firmly on to the machine reference edge.
- Working in three steps, tighten the mounting bolts on the profile rail using a torque spanner to the specified tightening torque.

Note

For a listing of the optimum torques for the screws, see section [5.5](#) on [page 41](#).

Fig. 5.7: Tensioning using a terminal block

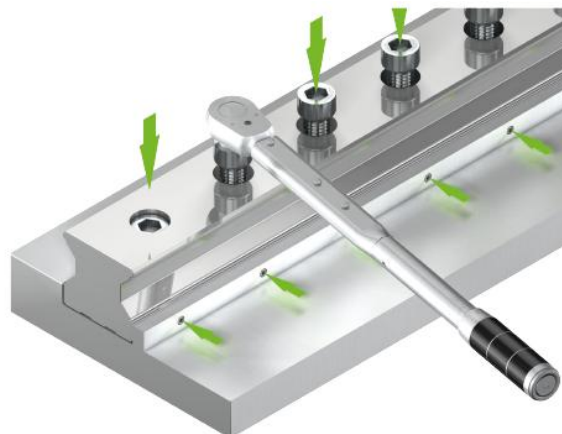

- ✓ The profile rail has been mounted.

Tensioning of the profile rail using vices:

- Use the vices to press the profile rail against the machine bed's reference edge.
- Tighten the profile rail's mounting bolts.
- Repeat this process for all fixing points.
- Working in three steps, tighten all mounting bolts on the profile rail using a torque spanner to the specified tightening torque.

Note

For a listing of the optimum torques for the screws, see section [5.5](#) on [page 41](#).

Fig. 5.8: Tensioning using vices

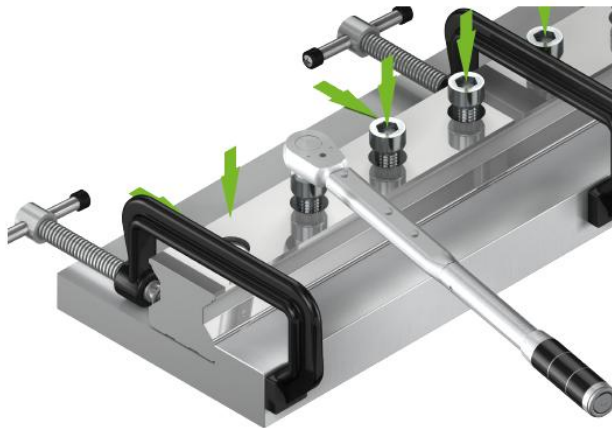

- ✓ The profile rail has been mounted.

5.2.4.1 Assembling the profile rail without a reference edge

- Mount a block on the reference rail.

Note

Mount the block according to section [5.4.2 Assembly](#).

- Mount a dial gauge on the block.
- Align the dial gauge with a reference edge.

Note

The reference edge should stretch from the beginning to the very end of the machine bed so that the profile rail can be aligned across the entire length of the machine bed.

- Move the profile rail a few centimetres along the reference edge using the block and align it.
- Tighten the profile rail's mounting bolts.
- Repeat this process for all fixing points.
- Tighten the mounting bolts using a torque spanner to the specified tightening torque.

Note

For a listing of the optimum torques for the screws, see section [5.5](#) on [page 41](#).

Fig. 5.9: Block with mounted dial gauge

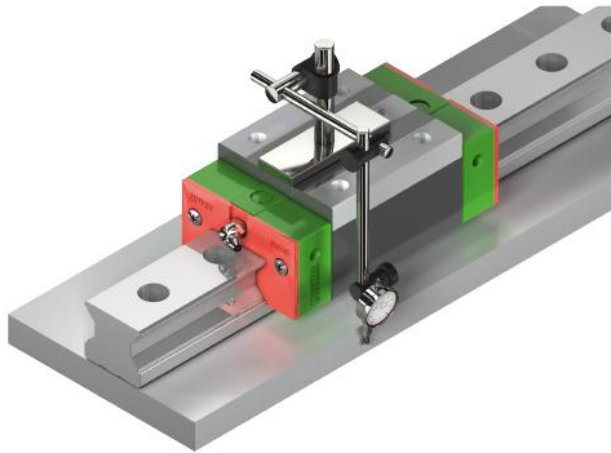

- ✓ The profile rail has been mounted.

5.2.5 Mounting the profile rail on the follow-on side

5.2.5.1 Requirements

- A reference rail must be mounted.
- A block is mounted on the reference rail.

5.2.5.2 Aligning the follow-on rail with a reference rail using a dial gauge

- Place the dial gauge on the mounted block of the aligned reference rail.
- Attach the dial gauge sensor to the follow-on rail.

Fig. 5.10: Scanning and aligning the follow-on rail with the reference rail

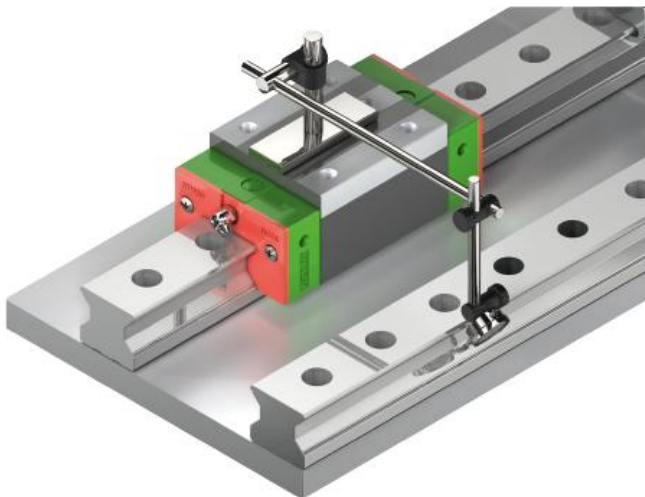

- Using the block that the dial gauge is mounted on, gradually move the follow-on rail over the reference rail.
- Tighten the mounting bolts of the next rail one after the other, working from one end of the guideway to the other.
- Tighten the mounting bolts using a torque spanner to the specified tightening torque.

Note

For a listing of the optimum torques for the screws, see [5.5 on page 41](#).

- ✓ The follow-on rail is mounted and aligned parallel with the reference rail.

5.2.5.3 Aligning the follow-on rail with a reference rail using a plate

- Mount a plate on two blocks on the aligned reference rail.
- Mount the other side of the plate on two blocks on the follow-on rail to be aligned.
- ✓ This setup results in the second rail being positioned in parallel.
- Gradually move the plate over the rails.

Fig. 5.11: Plate mounted on the block

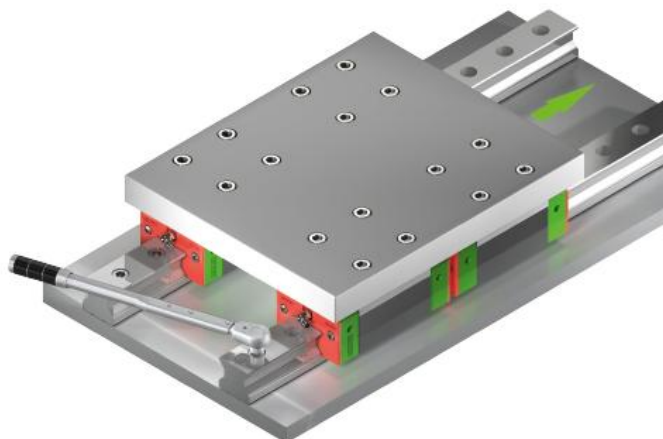

- Tighten the mounting bolts of the next rail one after the other, working from one end of the guideway to the other.
- Tighten the mounting bolts using a torque spanner to the specified tightening torque.

Note
For a listing of the optimum torques for the screws, see section 5.5 on page 41.

- ✓ The follow-on rail is mounted and aligned parallel with the reference rail.

5.2.6 Mounting of attached profile rails

Attached (multi-part) rails must be mounted according to the applied markings. The joints on each section are marked consecutively in alphabetical order and with the rail or pair number so that each rail section can be clearly assigned.

Fig. 5.12: Labelling of attached multi-part rails

	Part section 1		Part section 2		Part section 3	
	Shock A		Shock B			
Rail 1	S1.A	S1.A	S1.B	S1.B		
Rail 2	S2.A	S2.A	S2.B	S2.B		

Each joint is labelled on the top of the rail. The label provides help during initial assembly and can be removed at any time without leaving any residue.

Note
After initial assembly of the profile rails, the labels must be removed.

Fig. 5.13: Labelling of attached multi-part paired rails

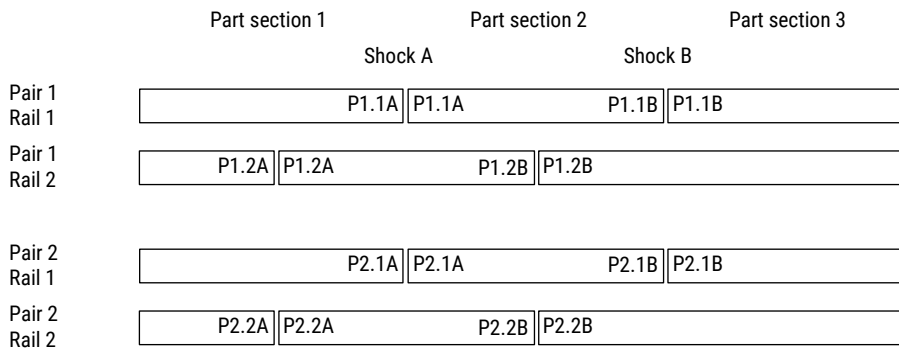

With paired multi-part rails, mounting the butt joints with an offset is recommended.

Fig. 5.14: Arrangement of attached multi-part rails

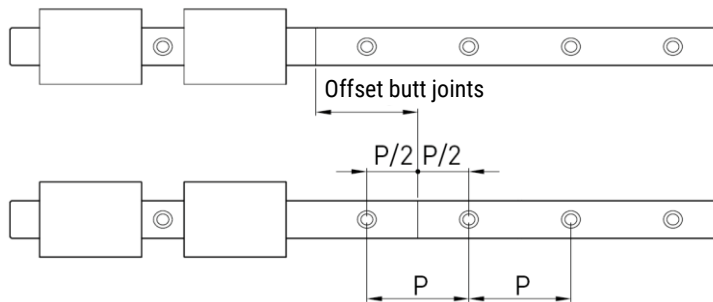

5.3 Covering the mounting holes

To protect the block from soiling and to protect the dust protection sealing lips, the profile rails' mounting holes must be closed using cover caps (in the case of R-rails, fixing is carried out from above). The type of cover depends on the environmental and operating conditions: plastic, steel or brass cover caps, or a cover strip, may be used. Plastic cover caps are generally recommended when using coated rails. Plastic cover caps are mounted as described in section 5.3.1.2. Steel and brass cover caps are pressed in using an assembly tool as described in section 5.3.1.3. The cover strip is mounted as described in section 5.3.2.

5.3.1 Cover caps

⚠ Caution! Damage caused by cover caps that have been incorrectly pressed in!

Pressing in the cover caps can result in a burr or result in the cover caps being pressed in too deep. This can later result in damage to the block and dust protection.

- ▶ Use an oil stone to remove any burrs that have occurred.
- ▶ Remove any cover caps that have been pressed in too deep and press in new cover caps.

5.3.1.1 Requirements

- The profile rails are mounted and fixed in accordance with the descriptions in section 5.2.4 / 5.2.5.
- The profile rails are free of dirt and oil (see section 7.1).

5.3.1.2 Mounting plastic cover caps

- Place the plastic cover cap centrally on the hole.
- Ensure parallelism between the top of the rail and the top of the cover cap.

Fig. 5.15: Positioning the plastic cover cap

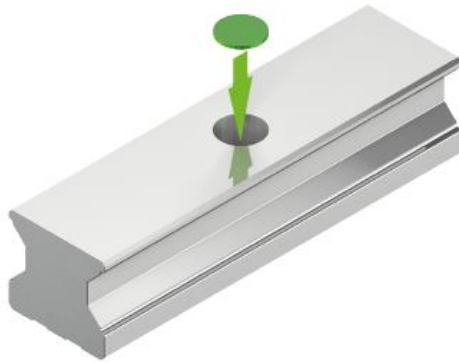

- Place a suitable press-in block vertically on the cover cap.
- Use a plastic hammer to drive the cover cap into the press-in block by hitting it in the centre.
- If the cover cap is not yet fully pressed in, repeat the described procedure until the cover cap is pressed in flush with the top of the profile rail.

Fig. 5.16: Pressing in the plastic cover cap using a press-in block

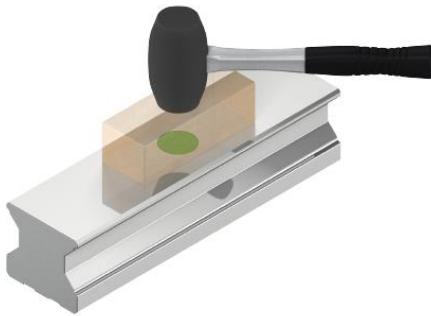
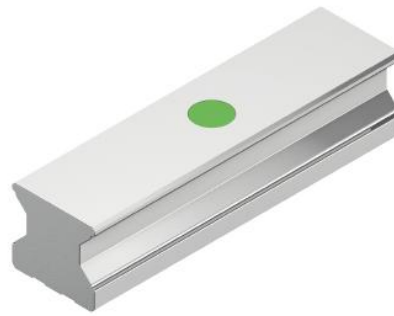

Fig. 5.17: Ready-mounted plastic cover cap



- ✓ The plastic cover cap is mounted.

5.3.1.3 Mounting steel or brass cover caps

Note

We recommend using the HIWIN assembly tool to ensure correct mounting of the steel and brass cover caps. Information on this can be found in section 11.2.

- Place the steel or brass cover cap centrally on the hole.
- Ensure parallelism between the top of the rail and the top of the cover cap.

Fig. 5.18: Positioning steel or brass cover cap

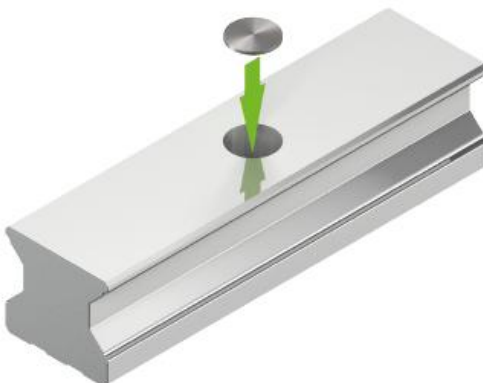

- Move the press-in block [4] (see Fig. 5.21) of the assembly tool [2] to the upper end position by loosening the screw [1].
- Slide the assembly tool onto the front of the profile rail.

Fig. 5.19: Positioning the assembly tool on the profile rail

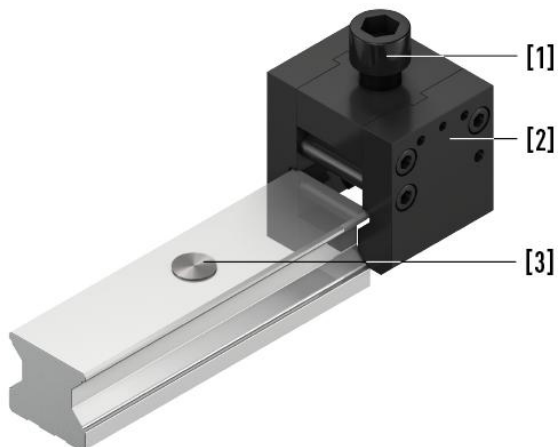

- Position the press-in block [4] (see Fig. 5.21) centrally over the hole or the cover cap [3].
- Move out the press-in block by tightening the screw [1] until the stamp makes contact with the cover cap and some resistance can be felt when tightening the screw.
- Before actually pressing in the cover cap, check to make sure the cover cap has not tilted.
- Press the cover cap in by continuing to tighten the screw [1] until the press-in block makes contact with the profile rail.

Note

The assembly tool must be greased at the following points (see Fig. 5.20)

Fig. 5.20: Greasing the assembly tool

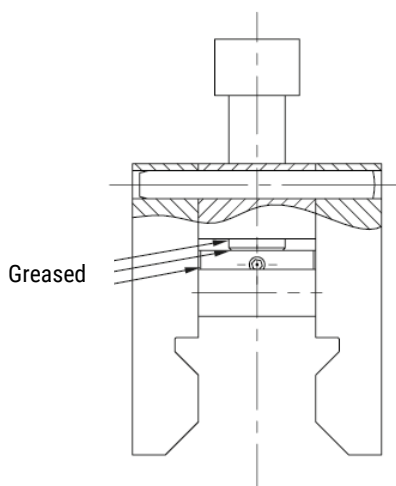

Note

The required tightening torque for pressing in the cover caps depends on several factors and can vary considerably. Please note the maximum values specified in Table 5.1.

Fig. 5.21: Pressing in the cover cap by tightening the screw

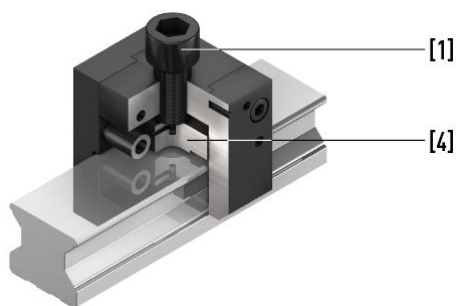

- Loosen the screw [1].
- Check the results of the pressing process.
- If the cover cap is not yet fully pressed in, repeat the described procedure.
- A burr may form while the cover cap is being pressed in.
- Remove this burr.

Fig. 5.22: Ready-mounted steel or brass cover cap



- ✓ The steel or brass cover cap is mounted.

Table 5.1: Recommended maximum tightening torques for pressing in steel and brass cover caps

Series/size	Cover cap		
	Brass ¹⁾	Steel ¹⁾	Maximum tightening torque [Nm]
HG15, RG15	5-001344	-	15
HG20, RG20	5-001350	5-001352	20
HG25, RG25	5-001355	5-001357	20
HG30, HG35, UR35, RG30, RG35	5-001360	5-001362	20
HG45, UR45, RG45	5-001324	5-001327	85
HG55, UR55, RG55	5-001330	5-001332	85
HG65, RG65	5-001335	5-001337	110

¹⁾ Not recommended for coated rails

5.3.2 Cover strip

⚠ Attention! Risk of injury due to sharp-edged cover strip!

The edges of the cover strips can be very sharp.

- ▶ Wear protective gloves when unpacking, assembling and disassembling!
- ▶ Prevent uncontrolled unfurling when the cover bands are rolled up by holding the ends of the bands!

ⓘ Caution! Damage to the linear guideway due to damaged cover strips!

Damaged cover strips impair dust protection and lead to premature wear of the linear guideway

- ▶ Avoid deformations and kinks as shown in [Fig. 5.23!](#)
- ▶ Replace damaged cover strips immediately!

Fig. 5.23: Damaged cover strip

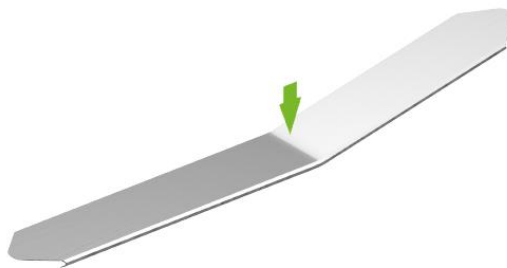

Note

In addition to the cover caps, a cover strip is available for the UR/CG/CRG series as an alternative way to close the mounting holes.

5.3.2.1 Delivery condition

One-piece profile rails are delivered with the cover strip mounted, as shown in [Fig. 5.24](#). The belt ends are folded and the belt clamps are mounted.

Fig. 5.24: Cover strip mounted on rail



For multi-part profile rails, the cover strip is supplied separately. The cover strip is delivered rolled up in a transport carton as shown in [Fig. 5.25](#). The cover strip clamps are enclosed.

Fig. 5.25: Cover strip in the transport box



5.3.2.2 Mounting the cover strip without a mounted block

Note

We recommend using the HIWIN assembly/disassembly tool to ensure correct mounting of the cover strip. Information on this can be found in section 11.2.

A. Positioning the cover strip

- Clean the profile rail using a suitable cleaning agent (see section 7.1).
- Place the cover strip on the profile rail.
- Maintain distance L_S in accordance with Table 5.2.

Fig. 5.26: Cover strip with machined tape end and distance L_S

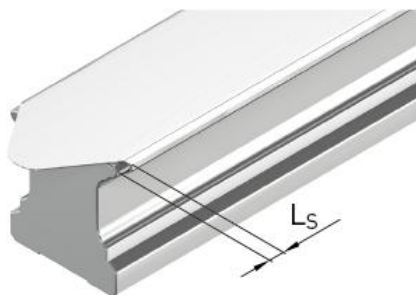

Table 5.2: Strip end distance

Size	Distance L_S [mm]
15	5.0
20	8.0
25	9.5
30	10.0
35	10.0
45	11.0
55	12.0
65	14.5

Note:

For cover strip length > 4000mm, follow steps "B1" and "B2".

B. Clamping the cover strip

- Clamp the cover strip onto the profile rail over a length of approx. 15 cm.
- To do this, press the fold of the cover strip on one side of the profile rail.
- Press down the second fold on the opposite side.

Fig. 5.27: Mounting the cover strip

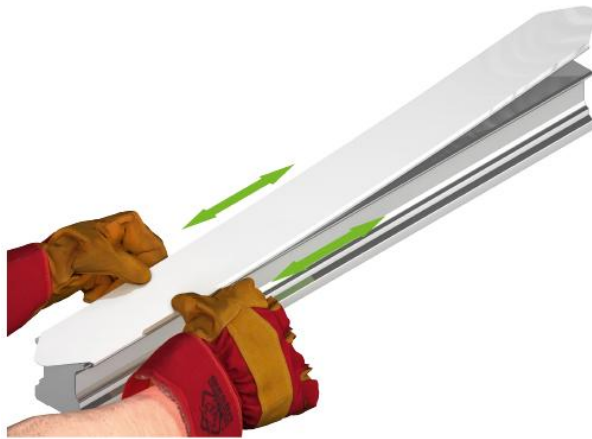

B1. Clamping the cover strip (only with cover strip > 4000 mm)

- Clamp the cover strip onto the profile rail over a length of approx. 3 cm.
- To do this, press the fold of the cover strip on one side of the profile rail.
- Press down the second fold on the opposite side.
- Cover strip is approx. 200 mm longer than the profile rail

Fig. 5.28: Clamp on cover strip approx. 3 cm



B2. Cutting the cover strip (only with cover strip > 4000 mm)

- Cut off approx. 100 mm of the protruding cover strip (see [Fig. 5.29](#))

Fig. 5.29: Cut off approx. 100 mm of the protruding cover strip

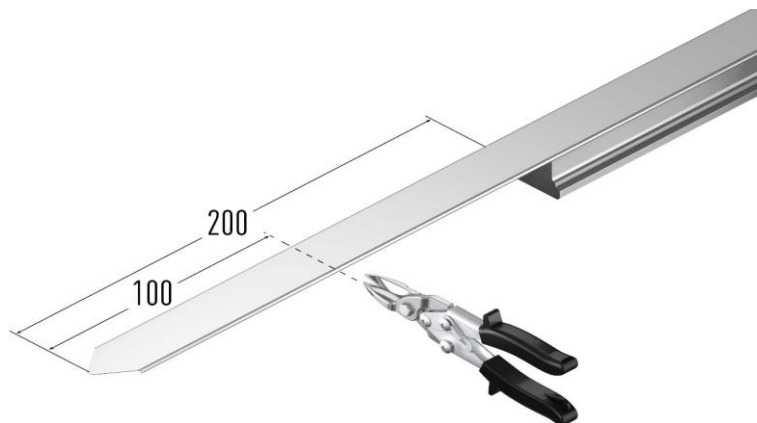

- Using the cut-off 100 mm of the cover strip as a template, position the template at the strip end of the profile rail (see Fig. 5.30 and Fig. 5.31). Note distance L_s at the end of the strip (see Table 5.2).

Fig. 5.30: Use the cut-off 100 mm as a template

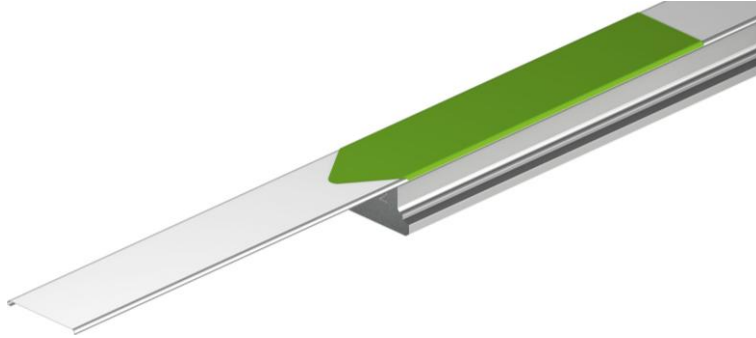

- Draw the outline on the cover strip using the template.

Fig. 5.31: Drawing contour

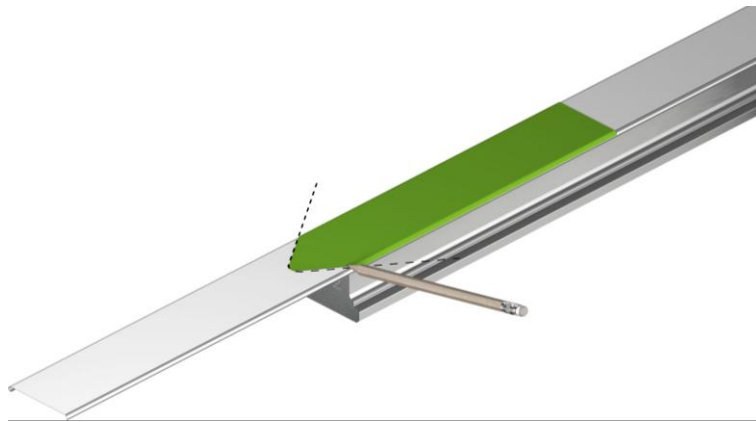

- Cut the contour of the cover strip with tin snips.

Fig. 5.32: Cutting the cover strip to size

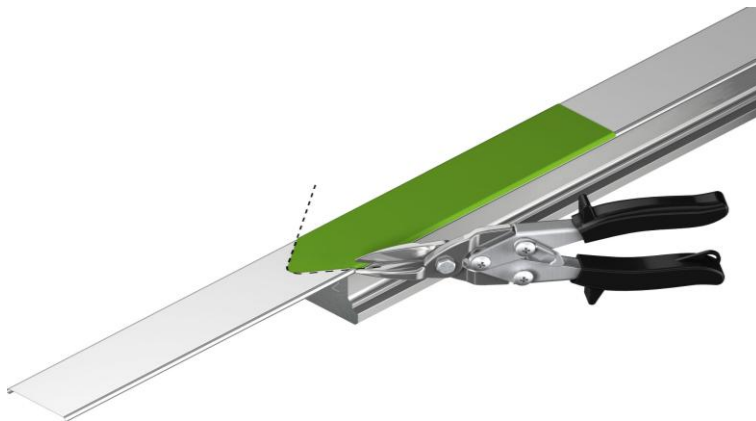

- Deburr the cut end of the strip with a file.
- If necessary, carefully correct the protruding corners of the cover strip with a hammer.

Fig. 5.33: Incorrectly and correctly touched up cover strip

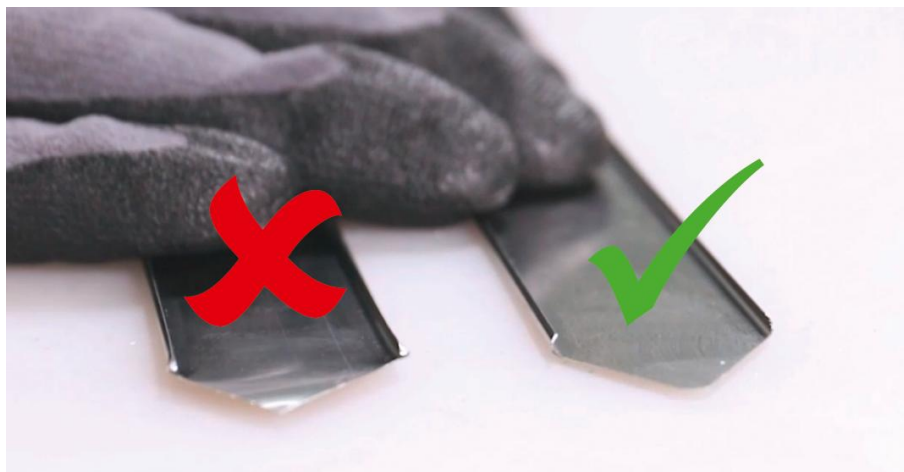

Fig. 5.34: Manually cut cover strip



C. Assembly using the HIWIN assembly tool

Note

We recommend using the HIWIN assembly/disassembly tool to ensure correct mounting of the cover strip. Information on this can be found in [section 11.2](#).

- Place the assembly tool on the front of the rail (see [Fig. 5.35](#)).
- Push the assembly tool over the entire rail.

Fig. 5.35: Mounting the cover strip using the assembly tool



- ✓ The cover strip is resting flush on the upper side of the profile rail.

Fig. 5.36: Correctly and incorrectly fitted cover strip

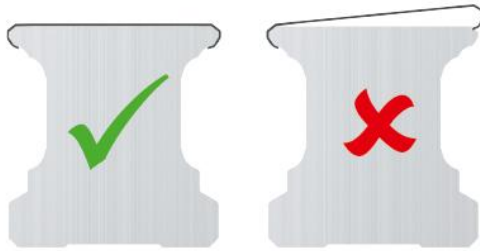

D. Bending over the strip ends

- Carefully bend the two strip ends of the cover strip with a rubber hammer.

Fig. 5.37: Bending over the strip ends

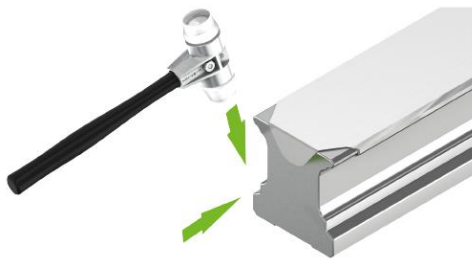

- ✓ The cover strip has been mounted.

5.3.2.3 Mounting the cover strip with a mounted block

! Caution! Damage to the cover strip!

Pushing the cover strip on to the rail or moving it under the block can result in the cover strip snapping off due to excessively high levels of pressure being exerted on it.

- ▶ Carefully slide the cover strip onto the rail!
- ▶ If the cover strip is difficult to slide on, repeat the steps described under B.

If a cover strip needs to be retrofitted or a damaged one needs to be replaced while one or more blocks are mounted on the rail, it is necessary to create a sliding range on the cover strip. An expanding mandrel is required for this purpose.

A. Setting the position of the sliding range

- Push the block as far as possible to the end of the rail
- Measure length L_L according to [Fig. 5.38](#) or [Fig. 5.39](#) from the start of the block to the end of the rail.
- The minimum length of the sliding range must be 150 mm longer than length L_L .

Note

The following maximum sliding ranges must not be exceeded:

- Rail without magnetic tape 1000 mm
- Rail with magnetic tape 500 mm

If larger sliding ranges are necessary due to the design, consult HIWIN.

Fig. 5.38: Sliding range (L_L)

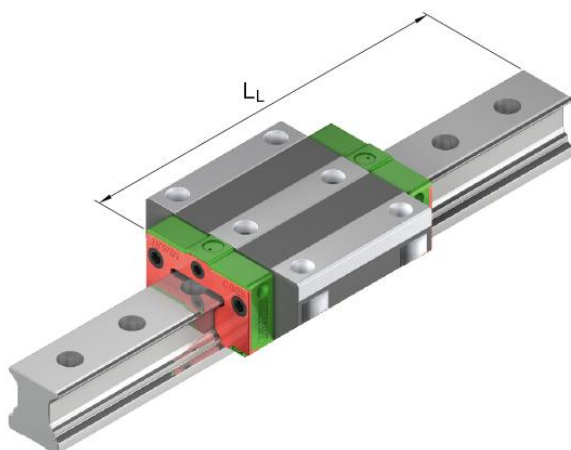
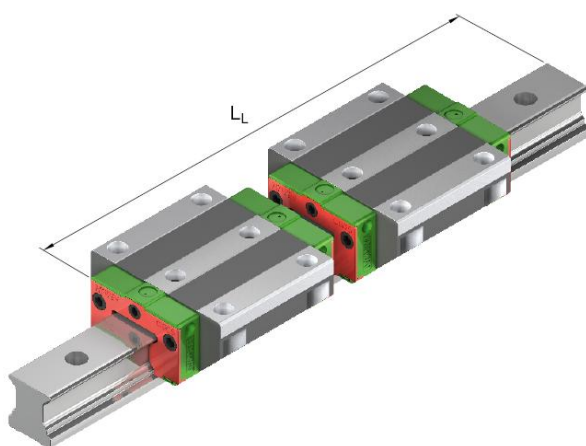

Fig. 5.39: Sliding range (L_L) with two blocks



B. Creating the sliding range

Note

We recommend using an expanding mandrel to widen the cover strip. For information, see section 11.2.

- Place the expanding mandrel on the inner end of the sliding range so that the flat sides are aligned parallel with the cover strip.
- Turn the mandrel 90°.
- Pull the mandrel with one hand to the beginning of the cover strip while holding it with the other hand.

Fig. 5.40: Widening the sliding range using the expanding mandrel

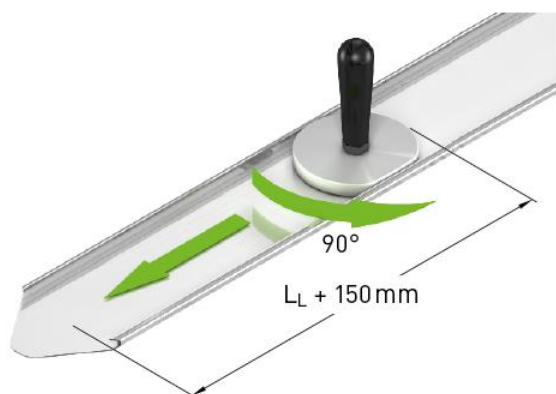

✓ The cover strip's sliding range has been widened.

C. Checking the sliding range

- Place the cover strip at the beginning of the profile rail.
- Push the cover strip slightly on to the profile rail.

Note

Repeat the steps in B if it is still not possible to push the cover strip on to the profile rail.

D. Assembly

- Clean the profile rail using a suitable cleaning agent (see section 7.1).
- Position the block as close as possible to the end of the profile rail.
- Push the cover strip on to the profile rail. The widened sliding range must be pushed under the block at this point.
- To facilitate this and minimize friction, you can:
 - - Hold the non-widened range upwards (see Fig. 5.41).
 - Carefully pull the cover strip from the other side of the block (see Fig. 5.42).

Note

Ensure that the strip does not snap.

Note

For rails with magnetic tape, make sure that the magnetic tape is not displaced during cover strip assembly. (See Fig. 5.43)

Fig. 5.41: Hold the non-widened area upwards

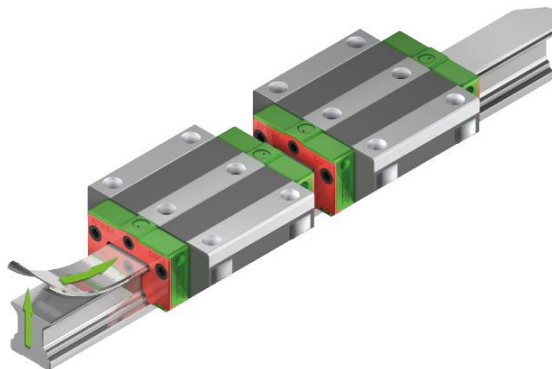

Fig. 5.42: Carefully pull from the other side of the block

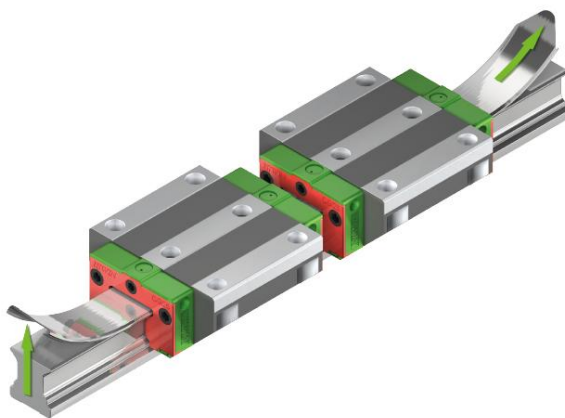
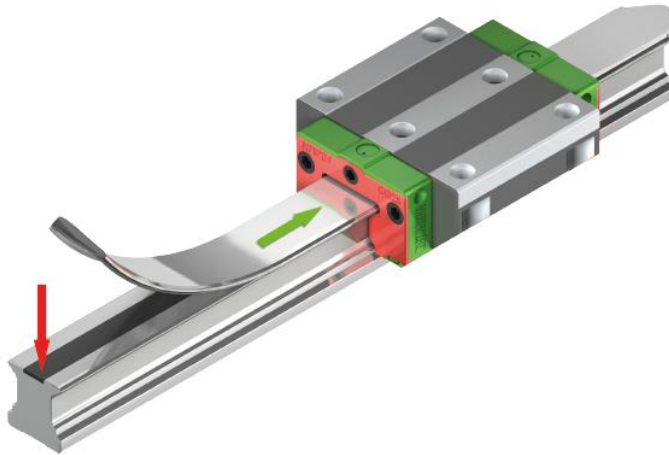

Fig. 5.43: Do not move the magnetic tape during assembly



- Place the cover strip on the profile rail.

Note

Distance L_s must be maintained in accordance with [Table 5.2](#).

- Press down the cover strip fold that has not been widened on the reference side of the profile rail.
- Press down the second fold on the opposite side.

Fig. 5.44: Mounting cover strip on the rail

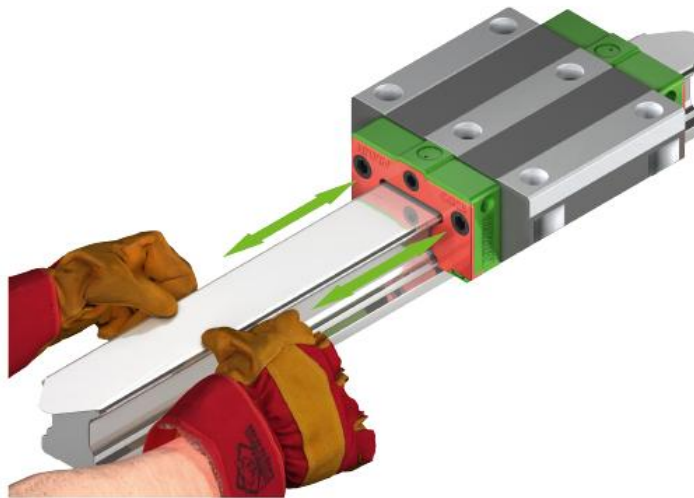

- ✓ The cover strip is resting flush on the upper side of the profile rail.

Fig. 5.45: Correctly and incorrectly fitted cover strip

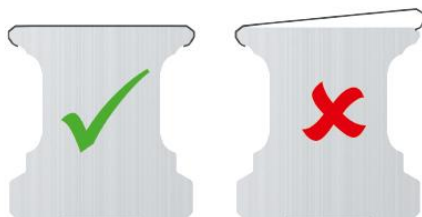

- Carefully bend the two strip ends of the cover strip with a rubber hammer (see Fig. 5.46).

Fig. 5.46: Bending over the strip ends

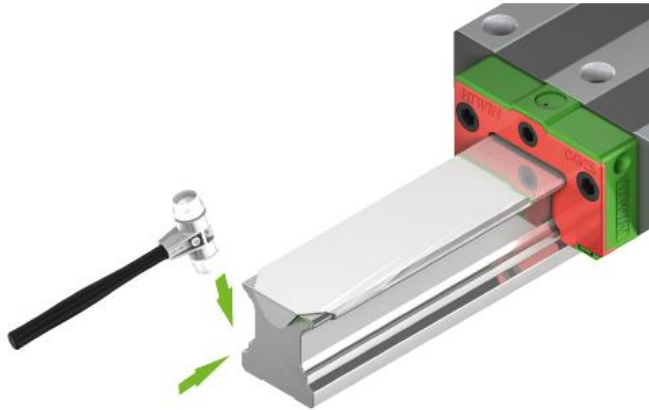

- ✓ The cover strip has been mounted.

5.3.3 Strip securing

To prevent the cover strip lifting up, it is secured at both front sides of the profile rail. There are two different methods of securing the strip:

- Securing the strip via steel clamps
- Securing the strip via front-side clamping bolts

5.3.3.1 Requirements

- The profile rail has been mounted.
- The cover strip has been mounted.
- The block has been mounted.

5.3.3.2 Securing the strip using steel clamps

- Place the steel clamps [2] on both sides of the profile rail.
- Screw in the allen set screw [1] until the steel clamps are fixed securely.

Fig. 5.47: Placing the steel clamps on the profile rail

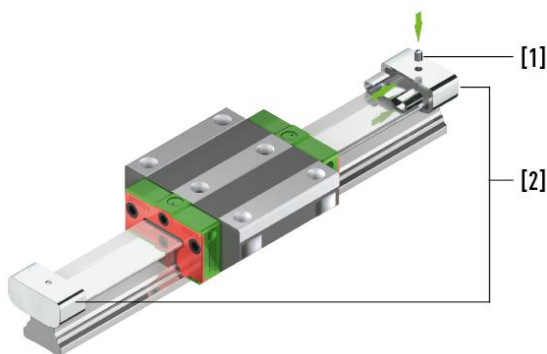
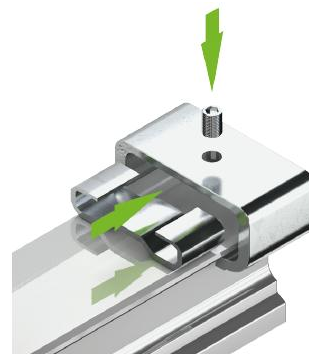

Fig. 5.48: Mounting the steel clamp



- ✓ The strip has been secured.

5.3.3.3 Securing the strip using front-side clamping bolts

- Screw the clamping bolts [3] to the front sides of the profile rail.

Fig. 5.49: Mounting the front-side strip securing method

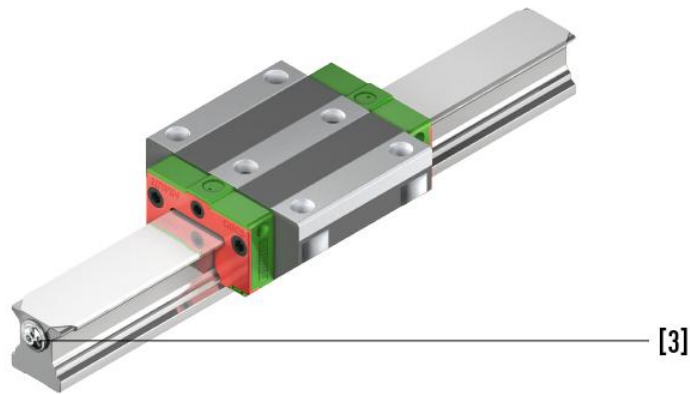

- ✓ The strip has been secured.

5.3.4 Dismantling the cover strip

Note

We recommend using the HIWIN assembly/disassembly tool to ensure correct disassembly of the cover strip. Information on this can be found in section [11.2](#).

- Lift the cover strip on the front side of the profile rail using the disassembly tool [1] (see [Fig. 5.50](#)).
- Lift it carefully over the entire length of the rail.

Note

For rails with magnetic tape, make sure that the magnetic tape is not displaced during cover strip disassembly.

Note

Ensure that the cover strip does not snap.

Fig. 5.50: Dismantling the cover strip

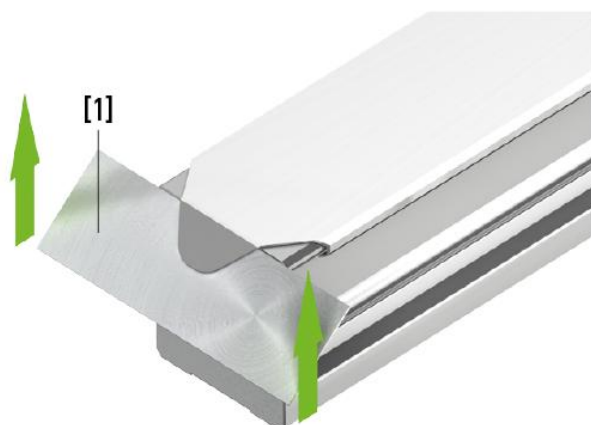

5.4 Block

! **Caution!** Damage to the block can be caused by removing the block insert too early.

Removing the block insert too early can cause damage to the block and result in rolling elements being lost.

- ▶ Remove the block insert only by pushing on the block!

! **Caution!** Damage to the block can be caused if cut edges have not been deburred.

Cut edges that have not been deburred can damage the end seals on the block.

- ▶ Always check the cut edges of the profile rail (if necessary cover strip) for burrs!
- ▶ If necessary, remove burrs with an oil stone or a brass wire brush.

Note

We generally recommend a chamfer on the end face of the profile rail for mounting the blocks.

5.4.1 Requirements

- The end seals on the block have been greased. This makes assembly easier and reduces the risk of damage to the seal during assembly.

5.4.2 Assembly

Note

Be careful when pushing the block on to the profile rail:

Blocks with medium and high preloads require more force to push them on compared to those with low preloads. Ideally, blocks with high preloads should be delivered already mounted.

Note

Please bear in mind the following when working with R-rails (with bored holes for mounting from above):

Provided that the mounting holes have not yet been sealed with cover caps or a cover strip, reduce the amount by which the block moves on the profile rail to a minimum. Otherwise, the dust protection sealing lips can become damaged.

- Attach the block to the rail in the required mounting direction on the front side, so that it is resting flush on the rail.
- Carefully push the block on to the rail.

Note

During this process, make sure that the block does not tilt.

Fig. 5.51: Pushing the block on to the profile rail.

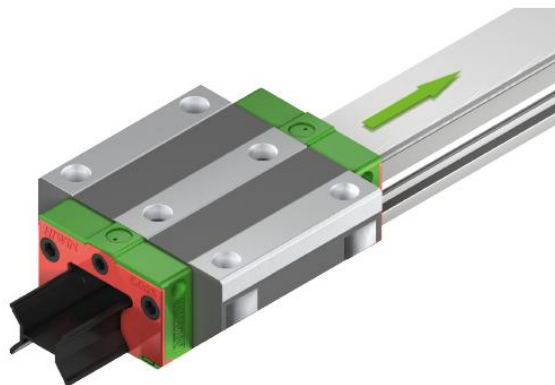

- ✓ The block insert is automatically pressed out and the block is mounted on the profile rail.

5.4.2.1 Special feature for mounting QH, QE and QW blocks

⚠ Caution! Damage to the block if the maximum screw-in depth is not observed!

The block mounting holes for the HIWIN linear guideways in the QH, QE and QW series are linked to the ball return channels (see Fig. 5.52). Using screws that are too long can damage the rolling elements.

▶ Do not exceed the maximum screw-in depths indicated in [Table 5.3!](#)

Note:

Fluids must not be used as thread lockers.

Fig. 5.52: Illustration of mounting hole and ball return channel

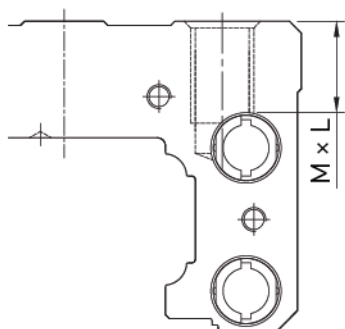

Table 5.3: Maximum screw-in depth – QH, QE and QW blocks

Model	Max. screw-in depth M x L [mm]	Model	Max. screw-in depth M x L [mm]
QHH20	M5 x 6	QEH25	M6 x 9
QHH25	M6 x 8	QEH30	M8 x 10
QHH30	M8 x 10	QWH27	M6 x 6
QHH35	M8 x 12	QWH35	M8 x 8
QEH20	M5 x 7		

Note

The linear guideway's load-bearing capacity is often restricted – not by its load-bearing strength, but by the screw connection. We therefore recommend checking the screw connection's maximum permissible load-bearing capacity in accordance with VDI 2230.

5.4.2.2 Specific features to bear in mind when assembling an adjacent structure on UR, RG, QR and CG series blocks

Each block in the UR, RG, QR and CG series is provided with two additional central threaded holes. These are sealed with green seal stoppers on delivery.

In order to achieve high rigidity for the linear guideway even in cases of high loads, we generally recommend using all available threaded holes to fix the adjacent structure in place.

Note

In blocks from the URW, RGW and QRW series, you also have the option of securing your adjacent structure from below. Before the block is assembled, it must be secured to the adjacent structure.

5.5 Tightening torques of the mounting bolts

Insufficient tightening of the mounting bolts severely affects the accuracy of the linear guideway; the following tightening torques for the respective screw sizes are recommended.

Table 5.4: Tightening torques of mounting bolts ISO 4762-12.9

Screw size	Torque [Nm]	Screw size	Torque [Nm]
M2	0.65	M8	40
M3	2.3	M10	70
M4	5.0	M12	100
M5	10.0	M14	170
M6	18.0	M16	250

Note

Recommended tightening torques of 12.9 DIN EN ISO 4762
Fixing screws according to VDI 2230 for $\mu_K = \mu_G = 0.125$

Note

Screw-in depth at least $2 \times$ thread diameter

Note

The linear guideway's load-bearing capacity is often restricted – not by its load-bearing strength, but by the screw connection. We therefore recommend checking the screw connection's maximum permissible load-bearing capacity in accordance with VDI 2230.

Note

Each block in the URW, RG, QR and CG series is provided with two additional central threaded holes. These are sealed with green seal stoppers on delivery.

In order to achieve high rigidity for the linear guideway even in cases of high loads, we generally recommend using all available threaded holes to fix the adjacent structure in place.

6 Commissioning

⚠ Attention! Risk of damage to health and the environment!

Contact with lubricants can cause irritation, poisoning and allergic reactions as well as damage to the environment.

- ▶ Only use suitable substances that are safe for humans. Observe the manufacturer's safety data sheets.
- ▶ Dispose of substances appropriately.

! Caution! Risk of damage to the linear guideways due to missing or incorrect lubrication!

Lack of initial lubrication or excessive lubricant quantities/pressure can damage or destroy the product.

- ▶ Never put the linear guideway into operation without initial lubrication!
- ▶ The specified work steps must be followed without fail in order to avoid damage to the product!

Note

If you have ordered a mounted linear guideway, remove the green stoppers before commissioning. These stoppers secure the block on the profile rail.

The standard lubrication conditions for the products can be found in section [8.10](#). Please follow the commissioning instructions in accordance with section [8.11](#).

7 Maintenance and cleaning

Maintenance is only required in the form of lubrication. See chapter [8](#).

7.1 Cleaning

! Caution! Damage to the linear guideway due to improper cleaning!

Using non-approved cleaning agents and tools can cause damage to the profile rail.

- ▶ Observe the legal regulations and the manufacturer's instructions for handling the cleaning products!
- ▶ Avoid damage to the profile rail by sharp objects!
- ▶ When cleaning, make sure that no metal particles get into or remain in the block!

Permissible cleaning and maintenance actions:

- Linear guideways can be cleaned with petroleum ether and oil.
- Trichloroethylene or a comparable cleaning agent can be used as a degreasing agent.
- To prevent corrosion, all parts must be dried, preserved or lubricated after cleaning.

8 Lubrication

8.1 Basic information on lubrication

Machine elements in linear technology require a sufficient supply of lubricants to ensure their function and service life.

The following specifications and notes are intended to assist the user in selecting a suitable lubricant, the appropriate lubricant quantity and determining the lubrication intervals.

These lubrication instructions do not release the user from checking the specified lubrication intervals in practice and correcting them if necessary. After each lubrication process, check whether there is sufficient lubricant on the machine element (check whether there is a lubricant film).

Lubricants

- Reduce wear and tear
- Protect from dirt
- Prevent corrosion

The lubricant is a constructional element and should be taken into consideration when designing a machine. When selecting the lubricant, the operating temperature range and the operating and ambient conditions must be taken into account.

8.2 Safety

! Caution! Damage due to incorrect lubricant!

Using the wrong lubricant can cause damage to property or environmental pollution.

- ▶ Use the correct type of lubricant (grease, oil) according to the specifications in these assembly instructions!
- ▶ Observe the manufacturer's safety data sheets.

8.2.1 Intended use of the lubricants

Prolonged and repeated contact with the skin should be avoided if possible. Clean wetted skin areas with soap and water. Use skin protection products during work and moisturising cream after work. If necessary, wear oil-resistant protective clothing (e.g. gloves, apron). Do not clean hands with petroleum, solvents, water-miscible or water-mixed cooling lubricants. Oil mist must be extracted at the point of origin.

Protective goggles must be worn to avoid eye contact. If eye contact nevertheless occurs, rinse the affected areas with plenty of water. If eye irritation persists, consult an eye doctor.

In case of accidental ingestion, do not induce vomiting under any circumstances. Immediate medical attention is required.

Safety data sheets according to 91/155/EEC are usually available for lubricants. Here you will find detailed information on health, accident and environmental protection.

Lubricants are usually products that are hazardous to water. That is why they must not get into the soil, water or sewage system.

8.2.2 Safety instructions for storing the lubricants

Lubricants must be stored in well-sealed packaging in a cool, dry location. They must be protected against direct sunlight and frost.

Lubricants must not be stored together with:

- Food
- Oxidising agents

8.3 Lubrication connectors

HIWIN profile rail blocks offer three options for attaching a lubrication connector:

- On the front end
- On the side
- From above

Note

Not all blocks have a lubrication connector.

8.3.1 Lubrication connector on the front side

It is possible to fit a lubrication adapter on both end faces of the block. Each lubrication connector that is not in use is sealed with a sealing screw. This is the HIWIN standard configuration.

Fig. 8.1: Lubrication connectors on the front

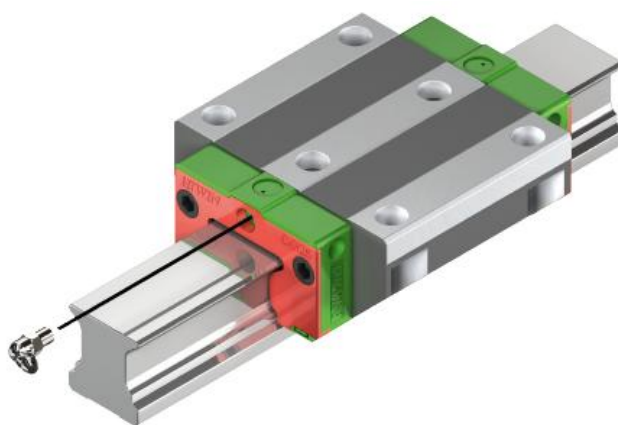

8.3.2 Lubrication connectors on the side

! Caution! Damage to the block due to improper opening of the lubrication hole!

- ▶ Do not use drills to open the lubrication hole, otherwise there is a risk of chips entering the block!

Note

In the CG series, these holes are prepared so they are ready for use and sealed with a sealing screw.

Fig. 8.2: Lubrication connector on the side

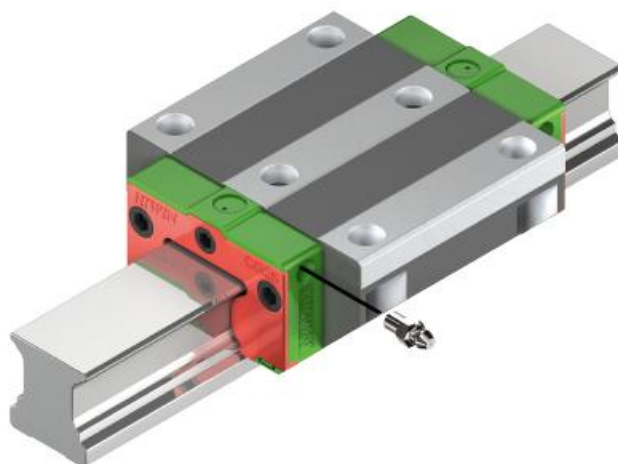

The block has a hole in both plastic deflectors on the left and right to attach a lubrication adapter to the side.

For series HG, QH, EG, QE, WE, QW, RG and QR, a thread must be cut into the prepared side hole using a blind hole tap. The maximum thread depth according to [Table 8.1](#) must not be exceeded. Then clean the hole; it must be free of chips and other impurities. Finally, the lateral lubrication hole in the base must be opened using a metal mandrel.

Diameter of the metal mandrel:

- Diameter 2.5 mm up to size 35
- Diameter 3.0 mm from size 45

Note

If the first wall is broken through, do not press any further, otherwise there will be a breakthrough into the recirculation system of the rolling elements.

Note

When using the side lubrication connector, it should not be fitted on the reference side, but on the opposite side. Should it be necessary to mount the lubrication connector on the reference side, make sure that the lubrication connector does not protrude beyond the reference side of the block. Opened lateral lubrication holes can be closed with a sealing screw if necessary.

Note

Straight taper or ball grease nipples are used for lateral lubrication. For flanged blocks, we recommend the use of the respective HIWIN lubrication adapters according to [Table 8.1](#) due to the small distance between block flange and grease nipple. Alternatively, funnel grease nipples can also be used.

Table 8.1: Lateral lubrication hole – dimensions and grease nipple

Block type	Thread	Thread length in mm
HG 15 EG 15 RG 15, 20 CRG 15, 20 WE 21, 27 QW 21, 27	M4	4.5
HG 20, 25, 30, 35 QH 20, 25, 30 EG 30, 35 QE 25, 30, 35 CG 25, 30, 35, 45 WE 21, 27, 35 QW 21, 27, 35 RG 25 CRG 25 QR 25	M6 × 0.75	6
HG 45, 55, 65 QH 45 RG 45, 55, 65 CRG 45, 55, 65 QR 45	1/8 PT	10
QH, QE 15, QR 20	M4	4.5
QH 35 UR35, UR45, UR55 RG 30, 35 CRG 30, 35 QR 30, 35	M6 × 0.75	6
EG 20, 25 QE 20	M6 × 0.75	6
CG 15, 20 WE 17 QW 17	M3	4.5
WE 50	1/8 PT	10.0

8.3.3 Lubrication connector from above

Fig. 8.3: Lubrication connector from above

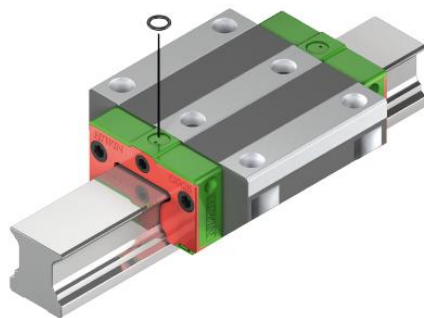

Fig. 8.4: Lubrication connector from above (HGH/QHH, CGH, URH, RGH/QRH), see section [8.3.3.1](#)

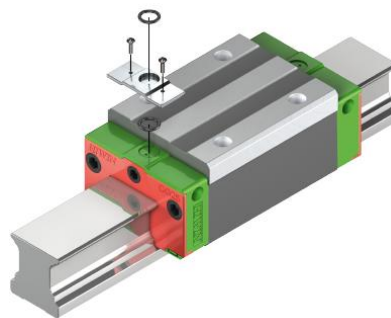

Fig. 8.5: Lubrication connector from above (application)



Lubrication of the block can also be done from above. In this case, an O-ring is used as a seal. See Table 8.2 for the size of the O-ring. If you order the block with the option of lubrication from above selected, the lubrication hole will be open and the required O-ring enclosed. If the block is ordered without lubrication, the hole must first be opened.

In the recess for the O-ring, there is a further recess.

- Open them with a 1.5 mm diameter drill to a maximum depth of T_{max} according to Table 8.2.

Note

Once lubrication holes have been opened for lubrication from above, they can no longer be closed with a sealing screw.

Fig. 8.6: O-ring for covering the lubrication connector from above

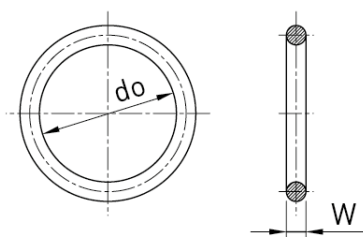

Fig. 8.7: Maximum penetration depth T_{max}

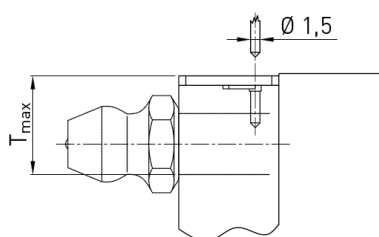

Table 8.2: Specifications of O-ring for lubrication connector from above

Series/Size	O-ring			Lubrication hole from above
	Article number	do [mm]	W [mm]	Max. depth T _{max} [mm]
HG/QH_15	20-000386	2.5 ± 0.15	1.5 ± 0.15	3.75
HG/QH_20	20-000387	4.5 ± 0.15	1.5 ± 0.15	5.70
HG/QH_25	20-000387	4.5 ± 0.15	1.5 ± 0.15	5.80
HG/QH_30	20-000387	4.5 ± 0.15	1.5 ± 0.15	6.30
HG/QH_35	20-000387	4.5 ± 0.15	1.5 ± 0.15	8.80
HG/QH_45	20-000387	4.5 ± 0.15	1.5 ± 0.15	8.20
HG_55	20-000387	4.5 ± 0.15	1.5 ± 0.15	11.80
HG_65	20-000387	4.5 ± 0.15	1.5 ± 0.15	10.80
EG/QE_15	20-000386	2.5 ± 0.15	1.5 ± 0.15	6.90
EG/QE_20	20-000387	4.5 ± 0.15	1.5 ± 0.15	8.40
EG_25	20-000387	4.5 ± 0.15	1.5 ± 0.15	10.40
QE_25	80171785	3,0 ± 1.5	2.5 ± 0.15	10.40
EG/QE_30	20-000387	4.5 ± 0.15	1.5 ± 0.15	10.40
EG/QE_35	20-000387	4.5 ± 0.15	1.5 ± 0.15	10.80
CG_15	20-000386	2.5 ± 0.15	1.5 ± 0.15	3.75
CG_20	20-000387	4.5 ± 0.15	1.5 ± 0.15	5.70
CG_25	20-000387	4.5 ± 0.15	1.5 ± 0.15	5.80
CG_30	20-000387	4.5 ± 0.15	1.5 ± 0.15	6.30
CG_35	20-000387	4.5 ± 0.15	1.5 ± 0.15	8.80
CG_45	20-000387	4.5 ± 0.15	1.5 ± 0.15	8.20
WE_21	20-000386	2.5 ± 0.15	1.5 ± 0.15	4.20
WE_27	20-000387	4.5 ± 0.15	1.5 ± 0.15	5.80
WE/QW_35	20-000387	4.5 ± 0.15	1.5 ± 0.15	7.60
QW_21	20-000376	7.5 ± 0.15	1.5 ± 0.15	4.20
QW_27	20-000376	7.5 ± 0.15	1.5 ± 0.15	5.80
UR_35	20-000376	7,5 ± 0,15	1,5 ± 0,15	8.65
UR_45	20-000376	7,5 ± 0,15	1,5 ± 0,15	9.5
UR_55	20-000376	7,5 ± 0,15	1,5 ± 0,15	11.6
RG_15	20-000386	2.5 ± 0.15	1.5 ± 0.15	3.45
RG_20	20-000386	2.5 ± 0.15	1.5 ± 0.15	4.00
RG/QR_25	20-000376	7.5 ± 0.15	1.5 ± 0.15	5.80
RG/QR_30	20-000376	7.5 ± 0.15	1.5 ± 0.15	6.20
RG/QR_35	20-000376	7.5 ± 0.15	1.5 ± 0.15	8.65
RG/QR_45	20-000376	7.5 ± 0.15	1.5 ± 0.15	9.50
RG_55	20-000376	7.5 ± 0.15	1.5 ± 0.15	11.60
RG_65	20-000376	7.5 ± 0.15	1.5 ± 0.15	14.50

Note

It may be necessary to use spacers (HIWIN lubrication adapters) to mount the lubrication.

8.3.3.1 Spacers (lubrication adapter)

For series HG/QH, UR, RG/QR and CG (types HGH/QHH, RGH/QRH and CGH), spacers (lubrication adapter TCN, Top-CoNnector) must be fitted to compensate for the difference in height between the deflector and the block mounting surface.

The adapters are only delivered assembled, the matching O-ring is included in the scope of delivery when ordering this option.

Availability of lubrication adapter TCN:

- HG/QH_15, HG/QH_25, HG/QH_30, HG/QH_35, HG/QH_45, HG_55
- RG_15, RG_20, RG/QR_25, RG/QR_30, UR/RG/QR_35, UR/RG/QR_45, UR/RG_55
- CG_25, CG_30, CG_35, CG_45

Fig. 8.8: Structure of lubrication adapter

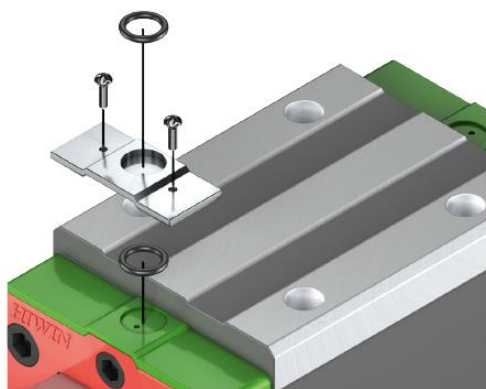

8.3.4 Grease nipple Lubrication adapters and push-in fittings

Various grease nipples, lubrication adapters and push-in fittings are optionally available.

Fig. 8.9: Grease nipple

Fig. 8.10: Lubrication adapters

Fig. 8.11: push-in fittings

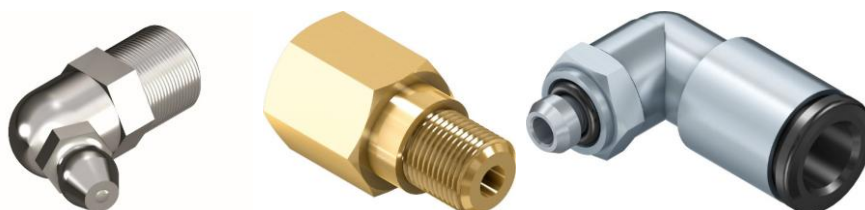

Information on the appropriate lubrication connector for your block, depending on the sealing system, can be found in the lubrication connector configurator at hiwin.de.

8.4 Use of central lubrication systems

If a central lubrication system is used, carrying out the initial lubrication (see section 8.11) separately with a manual grease gun before connecting it to the system is recommended. Also make sure that all lines and elements up to the consumer are filled with lubricant and do not contain any air pockets.

Long cable runs and small cable diameters should be avoided. The cables are to be laid uphill. The pulse number results from the partial quantities and the piston distributor size. In addition, the lubrication system manufacturers' instructions must be observed.

8.5 Lubricating pressure

HIWIN linear guideways can be lubricated using oil, grease or low-viscosity grease, depending on the specific application. The required lubricating pressure depends on the size, the lubricant, the length of the feed line and the type of lubrication connector used.

Minimum lubricating pressure on the block:

- Grease or low-viscosity grease: 6 bar
- Oil lubrication: 3 bar

The maximum permissible lubricating pressure on the block is 30 bar.

! **Caution!** Damage to the block can be caused by excessive lubricating pressure levels or lubricant quantities.

Seals are at particular risk of damage on blocks with double seals, SW seals or ZWX seals.

- ▶ Carry out lubrication according to the assembly instructions.
- ▶ Make sure you use the right lubricating pressure levels and lubricant quantities.

8.6 Selecting a lubricant

Oils, greases or low-viscosity greases can be used as lubricants. The same lubricants are used as for rolling bearings. As a rule, the selection of a lubricant and the infeed method can be adapted to fit in with the lubrication of the other machine components.

Essentially, the selection of a lubricant depends on the operating temperature and various operation-related factors, e.g. load, vibrations, oscillation or short-stroke applications. Special requirements – such as use in combination with strong or aggressive media, in clean rooms, in a vacuum or in the food industry – also need to be considered.

Grease lubrication

For grease lubrication, we recommend lubricating greases for rolling bearings and friction bearings with mineral oil as the base oil and thickeners specified by DIN 51825 (K1K, K2K). In heavy-duty applications, we recommend using EP additives (KP1K, KP2K), NLGI class 1 or 2. Using greases of other consistency classes is possible subject to the approval of the lubricant supplier.

Lubrication with low-viscosity grease

In centralised lubrication systems, low-viscosity greases are frequently used, as they are distributed more effectively over the whole system due to their soft structure.

Oil lubrication

Lubricating oils offer the advantage of more even distribution and reach the contact surfaces more effectively. However, this also means that lubricating oils collect in the lower area of the product as a result of the force of gravity and thus cause soiling more quickly. For this reason, higher quantities of lubricant are required than with grease lubrication. As a rule, oil lubrication is only suitable when centralised lubrication units are being used or for products equipped with a long-term lubrication unit.



Note

For wall mounting, we generally recommend grease or low-viscosity lubricant; for oil lubrication, we generally ask that you consult us, as insufficient lubrication may occur depending on the installation position.

8.6.1 Lubricant recommendations

The following table lists examples of applications and suitable lubricants.

⚠ Caution! Damage caused by using the wrong greases!

Greases with solid particles such as graphite or MOS_2 can cause damage.

▶ Do not use any grease containing solid particles such as graphite or MoS_2 !

Note

The information on lubricants serves to provide examples and is only intended as an aid to selection. Other lubricants may be selected after clarification of the specific application with the lubricant supplier. In addition, the lubrication system manufacturers' instructions must be observed.

Table 8.3: Recommended lubricants – grease, low-viscosity grease and oil

Type of application	Grease		Low-viscosity grease		Oil	
	Manufacturer	Description	Manufacturer	Description	Manufacturer	Description
Standard	HIWIN	G05	Klüber Lubrication München	MICROLUBE GB 00	Klüber Lubrication München	Klüberoil GEM 1-150 N
	Klüber Lubrication München	MICROLUBE GL 261	Mobil	Mobilux EP 004	FUCHS	GEARMASTER CLP 320
	Mobil	Mobilux EP 1	FUCHS	GEARMASTER LI 400	FUCHS	RENOLIN CLP 150
	FUCHS	LAGERMEISTER BF 2	FUCHS	RENOLIT EPLITH 00	-	-
	LUBCON	Turmogrease CAK 2502	-	-	-	-
	FUCHS	RENOLIT LZR 2 H	-	-	-	-
	Klüber Lubrication Munich ¹⁾	ISOFLEX TOPAS AK 50 ¹⁾	-	-	-	-
Heavy load	HIWIN	G01	We recommend that you consult a lubricant manufacturer regarding the use of these lubricants for heavy-duty applications.			
	Klüber Lubrication München	Klüberlub BE 71-501				
	FUCHS	LAGERMEISTER EP 2				
	LUBCON	TURMOGREASE Li 802 EP				
	FUCHS	RENOLIT LZR 2 H				
Clean room	HIWIN	G02	We recommend that you consult a lubricant manufacturer regarding the use of these lubricants for heavy-duty applications.		Klüber Lubrication München	Klüber Tyreno Fluid E-95V
	Klüber Lubrication München	ISOFLEX TOPAS NCA 152			Mobil	Mobilgear 626
	FUCHS	GLEITMO 591			FUCHS	RENOLIN CLP 100
Clean room with high speeds	HIWIN	G03	-	-	-	-
	Klüber Lubrication München	ISOFLEX TOPAS NCA 52	-	-	-	-
High speeds	HIWIN	G04	Klüber Lubrication München	ISOFLEX TOPAS NCA 5051	Klüber Lubrication München	Klüberoil GEM 1-46 N
	Klüber Lubrication München	ISOFLEX NCA 15	Mobil	Mobilux EP 004	FUCHS	RENOLIN ZAF B 46 HT
	LUBCON	Turmogrease Highspeed L 252	FUCHS	GEARMASTER LI 400	-	-

Type of application	Grease		Low-viscosity grease		Oil	
	Manufacturer	Description	Manufacturer	Description	Manufacturer	Description
	FUCHS	RENOLIT HI-Speed 2	FUCHS	RENOLIT SF 7-041	-	-
Short stroke and high frequencies	HIWIN	G06	Fuchs	Renolit G-FHT 00	Fuchs	Renotac 345
	Klüber Lubrication München	Microlube GL 261	Klüber Lubrication München	Microlube GB 0	Klüber Lubrication München	Klüberoil GEM 1-220
	Mobil	Mobilgrease XHP 222	-	-	-	-
Low temperatures	HIWIN	G07	Fuchs	Renolit GLS 00	Aral	Vitam HF 32
	Fuchs	Renolit S2	Klüber Lubrication München	Klübersynth UH 1 14-1600	Esso	Univis N 32
	Klüber Lubrication München	Isoflex LDS 18 Special A	-	-	-	-
Food grade according to USDA H1	Klüber Lubrication München	Klübersynth UH1 14-151	Klüber Lubrication München	Klübersynth UH1 14-1600	Klüber Lubrication München	Klüberoil 4 UH1-68 N
	Mobil	Mobilgrease FM 102	Mobil	Mobilgrease FM 003	-	-
	FUCHS	GERALYN 1	FUCHS	GERALYN 00	-	-

¹⁾ Recommended for MG series

8.6.1.1 Description of types of application

Standard applications

Load: max. 15% of the dynamic load rating
 Temperature range: -10 °C to +80 °C
 Speed: < 1 m/s

Heavy-duty applications

Load: max. 50% of the dynamic load rating
 Temperature range: 0 °C to +80 °C
 Speed: < 1 m/s

Clean room applications

Load: max. 50% of the dynamic load rating
 Temperature range: -10 °C to +80 °C
 Speed: < 1 m/s

Clean room applications with high speeds

Load: max. 50% of the dynamic load rating
 Temperature range: -10 °C to +80 °C
 Speed: > 1 m/s

Applications with high speeds

Load: max. 50% of the dynamic load rating
 Temperature range: -10 °C to +80 °C
 Speed: > 1 m/s

Short stroke and high frequencies

Load: Max. 50 % dynamic load rating
 Temperature range: -10 °C to +80 °C
 Acceleration: 15–30 m/s²

Low temperatures

Load: Max. 50 % dynamic load rating
 Temperature range: -50 °C to 0 °C
 Speed: < 1 m/s

Applications for the food sector according to USDA H1

Load: max. 15% of the dynamic load rating
 Temperature range: -10 °C to +80 °C
 Speed: < 1 m/s

8.7 HIWIN greases

Table 8.4: Overview of HIWIN greases

Grease type	Area of application	Article number	
		Cartridge 70 g	Cartridge 400 g
			
G01	Heavy-duty applications	20-000335	20-000336
G02	Clean room applications	20-000338	20-000339
G03	Clean room applications + high speed	20-000341	20-000342
G04	Heavy velocity	20-000344	20-000345
G05	Standard grease	20-000347	20-000347
G06	Short stroke and high frequencies	20-002195	20-002196
G07	Low temperatures	20-002197	20-002198

8.8 Miscibility of lubricants

The miscibility of different lubricants must be tested. Lubricating oils based on mineral oil with the same classification (e.g. CL) and similar viscosity (maximum one class difference) are miscible.

Greases are miscible if their base oil and thickening type are the same. The viscosity of the base oil must be similar. The NLGI class may differ by a maximum of one level.

If lubricants other than those specified are used, shorter relubrication intervals and reduced performance must be expected. Possible chemical interactions between plastics, lubricants and preservatives must be expected.

Table 8.5: Miscibility of HIWIN greases

	G01	G02	G03	G04	G05	G06	G07
G01	●	●	●	○	○	○	○
G02	●	●	●	●	●	●	●
G03	●	●	●	●	●	●	●
G04	○	●	●	●	●	●	●
G05	○	●	●	●	●	●	●
G06	○	●	●	●	●	●	●
G07	○	●	●	●	●	●	●

● Miscible ○ Partially miscible

Table 8.6: Compatibility of basic grease products with HIWIN greases

	G01	G02	G03	G04	G05	G06	G07
QH, QE, QW, QR	○	●	●	●	●	●	●

● Miscible ○ Partially miscible

Note

Recommendation:

In the case of lubricants that are only partially miscible, the old grease must be used up as far as possible before the new grease is introduced. The relubrication quantity with the new grease must be increased for a short time.

In the case of lubricants that are not miscible, the old grease must be completely used up before the new grease is introduced.

8.9 Grease guns and lubrication adapters

A1: Hydraulic gripping coupling

For conical grease nipples according to DIN 71412, outer diameter 15 mm

Fig. 8.12: A1



A2: Hollow mouthpiece (not available individually)

For conical and ball grease nipples to DIN 71412/ DIN 3402, outer diameter 10 mm

Fig. 8.13: A2



A3: Hollow mouthpiece with lubrication adapter

For ball grease nipples according to DIN 3402, outer diameter 6 mm

Fig. 8.14: A3



A4: Round mouthpiece with lubrication adapter

For funnel type grease nipples according to DIN 3405, outer diameter 6 mm

Fig. 8.15: A4



A5: Pointed mouthpiece with lubrication adapter

Fig. 8.16: A5



A6: Angled pointed mouthpiece with lubrication adapter

Fig. 8.17: A6



Set of lubrication adapters and nozzles

Fig. 8.18: Lubrication adapters and nozzles A3, A4, A5, A6



Set GN-400C: Grease gun large and adapter A1, A2

Fig. 8.19: GN-400C



Set GN-80M: Grease gun small and adapter A1, A2

Fig. 8.20: GN-80M



Table 8.7: Overview of HIWIN grease guns and accessories

Article number	Contents			Direct filling	Cartridge	Grease quantity per stroke
	GN-80M (Fig. 8.20)	GN-400C (Fig. 8.19)	Set of lubrication adapters and nozzles (Fig. 8.18)			
20-000352	■	-	-	■	70 g	0.5-0.6 cm ³
20-000332	■	-	■	■	70 g	0.5-0.6 cm ³
20-000353	-	■	-	■	400 g	0.8-0.9 cm ³
20-000333	-	■	■	■	400 g	0.8-0.9 cm ³
20-000358	-	-	■	-	-	-

Table 8.8: Overview of grease nipples and recommended grease gun adapter

	Grease nipple	Recommended grease gun adapters
	Ball grease nipple	
	M3 × 0.5 P	A2 ²⁾ , A3 ¹⁾
	M4 × 0.7 P	A2, A3 ¹⁾
	Conical grease nipple	
	M6 × 0.75 P	A1, A2 ¹⁾
	1/8 PT	A1, A2 ¹⁾
	Grease nipple cone	
	M3 × 0.5 P	A4
	M4 × 0.7 P	A4
	M6 × 0.75 P	A4

¹⁾ Optional for limited installation space

²⁾ Not possible for an MG15 block that is already mounted on the rail (use A3)

8.10 Standard lubrication condition of the linear guideways on delivery

Depending on the product group and scope of delivery, the linear guideways are delivered in the following states.

- **Preserved blocks** are wetted over the entire surface with an anti-corrosion oil. Before commissioning, initial lubrication must be carried out in accordance with section 8.11.
- **Basic greased blocks** are delivered with a reduced grease quantity. The lubrication channels are largely free of grease. This facilitates lubricant changeover and enables the changeover from grease to oil lubrication. The basic greasing is sufficient for mounting the linear guideway. Before commissioning, initial lubrication must be carried out in accordance with section 8.11.
- **Initial greased blocks** are greased with the recommended grease quantity according to section 8.13.

Table 8.9: Standard lubrication condition for blocks mounted on profile rails

Series	lubrication condition
HG, EG, CG, WE, QH, QE, QW, QR	Initial greasing
UR, RG, MG, CRG	Preserved

Table 8.10: Standard lubrication condition for blocks not mounted on profile rails

Series	lubrication condition
HG, EG, CG, WE, UR, RG, MG, CRG	Preserved
QH, QE, QW, QR	Basic grease

Note

For basic greasing of the linear guideways, a grease for rolling and slide bearing with mineral oil as the base oil and thickeners according to DIN 51825 (K2K), NLGI class 2, is used. Base oil viscosity for QR: 100 mm²/s at 40 °C; base oil viscosity for QH, QE, QW: 200 mm²/s at 40 °C.

Note

If the lubrication condition deviates from the standard stated here, the specific lubrication condition will be stated in the order confirmation.

8.11 Initial lubrication during commissioning

! **Caution!** Risk of damage to the linear guideways due to missing or incorrect lubrication!

Lack of initial lubrication or excessive lubricant quantities/pressure can damage or destroy the product.

- ▶ Never put the linear guideway into operation without initial lubrication!
- ▶ The specified work steps must be followed without fail in order to avoid damage to the product!

Note

During initial lubrication, the required quantity of grease is applied to the block in order to achieve the specified lubrication intervals. The lubrication channels are then completely filled with grease, a change from grease to oil lubrication is then no longer possible without cleaning the block.

8.11.1 Performance

- Apply the amount of grease specified in section [8.13](#) by slowly pressing the grease gun.
 - Move the block by about three block lengths.
 - Repeat this process two more times.
 - Move the block over the entire travel distance and check the entire profile rail to see whether a lubricant film can be detected.
- ✓ The initial lubrication process for the linear guideway has been carried out.

Note

If a lubricant film cannot be detected along the entire length of the profile rail, increase the quantity of lubricant used.

8.11.1.1 Initial lubrication for short-stroke applications

For short stroke applications (stroke < 2 × block length), initial lubrication must be carried out as follows:

Stroke < 2 × block length:

Provide lubrication connectors on both sides of the block and carry out lubrication according to section [8.11.1](#) for each lubrication connector.

Note

Stroke < 0.5 × block length: Please consult HIWIN.

8.11.1.2 Initial lubrication – MG series

A grease nipple for grease lubrication is available for size 15 in the case of miniature type MG. For sizes 2, 3, 5, 7, 9 and 12, we recommend using a suitable lubricant (e.g. Isoflex Topas AK 50).

- Apply the lubricant evenly to the ball bearing races along the entire length of the profile rail.
 - Move the block along the entire stroke.
 - Remove any surplus grease if necessary.
- ✓ The initial lubrication process for the MG linear guideway has been carried out.

Note

If minimum displacement resistance is required or the environmental conditions are very clean, we recommend lubricating the MG series with oil (see section [8.13.3](#)).

8.12 Changing lubricant

Before you change to a different lubricant, the entire block must be thoroughly cleaned. More information on this can be found in section 7.1.

Note

Lubricants only need to be removed if they cannot be mixed.

8.13 Lubricant quantities

Note

The lubricant quantities given below are guide values which may vary depending on the ambient conditions.

Note

If the linear guideways are installed vertically, to the side or with the linear guideway upwards, the relubrication quantities must be increased by approx. 50%.

8.13.1 Lubricant quantities for grease lubrication

Table 8.11: Lubricant quantity for grease lubrication – series HG, QH, EG, QE, CG, WE, QW, UR, RG, QR

Size	Initial lubrication partial quantity [cm ³]			Relubrication quantity [cm ³]		
	Medium load (S)	Heavy load (C)	Super heavy load (H)	Medium load (S)	Heavy load (C)	Super heavy load (H)
15, 17	0.2 (3 ×)	0.3 (3 ×)	–	0.2	0.3	–
20, 21	0.3 (3 ×)	0.5 (3 ×)	0.7 (3 ×)	0.3	0.5	0.7
25, 27	0.4 (3 ×)	0.8 (3 ×)	1.0 (3 ×)	0.4	0.8	1.0
30	0.6 (3 ×)	1.3 (3 ×)	1.7 (3 ×)	0.6	1.3	1.7
35	0.8 (3 ×)	1.9 (3 ×)	2.4 (3 ×)	0.8	1.9	2.4
45	–	3.8 (3 ×)	4.6 (3 ×)	–	3.8	4.6
50, 55	–	6.3 (3 ×)	7.7 (3 ×)	–	6.3	7.7
65	–	10.0 (3 ×)	13.5 (3 ×)	–	10.0	13.5

Table 8.12: Lubricant quantity for grease lubrication – MG series

Size	Initial lubrication partial quantity [cm ³]		Relubrication Quantity [cm ³]	
	Average load (C)	High load (H)	Average load (C)	High load (H)
MGN15	0,04 (3 ×)	0,06 (3 ×)	0,04	0,06
MGW15	0,07 (3 ×)	0,09 (3 ×)	0,07	0,09

8.13.2 Lubricant quantities for fluid grease lubrication

Note

The quantities for lubrication with fluid grease are identical to the lubricant quantities for grease lubrication.

8.13.2.1 Piston distributor size for metering units (single-line systems) for fluid grease lubrication

To ensure sufficient lubrication, the following minimum sizes for piston distributors to be used must be observed. The time interval between the individual lubrication pulses results from the relubrication quantity, the relubrication interval and the piston distributor size:

$$\text{Spacing of the lubrication pulses (km)} = \frac{\text{Piston distributor size (cm}^3\text{)}}{\text{Relubrication quantity (cm}^3\text{)}} \times \text{relubrication interval (km)}$$

8.13.3 Lubricant quantities for oil lubrication

When using a central lubrication system, make sure that all lines and elements up to the consumer are filled with lubricant and do not contain any air pockets. Long cable runs and small cable diameters should be avoided. The cables are to be laid uphill.

The pulse number results from the partial quantities and the piston distributor size. The interval between two pulses is calculated from the quotient of the number of pulses and the relubrication interval.

In addition, the lubrication system manufacturers' instructions must be observed.

8.13: Lubricant quantities for oil lubrication – series HG, QH, EG, QE, CG, WE, QW, UR, RG, QR

Size	Initial lubrication partial quantity [cm ³]			Relubrication quantity [cm ³]		
	Medium load (S)	Heavy load (C)	Super heavy load (H)	Medium load (S)	Heavy load (C)	Super heavy load (H)
15, 17	0.3 (3 ×)	0.3 (3 ×)	–	0.3	0.3	–
20, 21	0.5 (3 ×)	0.5 (3 ×)	0.5 (3 ×)	0.5	0.5	0.5
25, 27	0.7 (3 ×)	0.8 (3 ×)	1.0 (3 ×)	0.7	0.8	1.0
30	0.9 (3 ×)	1.0 (3 ×)	1.2 (3 ×)	0.9	1.0	1.2
35	1.2 (3 ×)	1.5 (3 ×)	1.8 (3 ×)	1.2	1.5	1.8
45	–	1.7 (3 ×)	2.0 (3 ×)	–	1.7	2.0
50, 55	–	2.5 (3 ×)	2.8 (3 ×)	–	2.5	2.8
65	–	4.5 (3 ×)	4.8 (3 ×)	–	4.5	4.8

Note

With miniature guide MG, we recommend oil lubrication via the profile rail. Apply the lubricant evenly, for example with a suitable brush, over the entire length of the profile rail on the ball tracks. Move the block along the entire stroke and remove excess oil.

8.13.3.1 Piston distributor size for metering units (single-line systems) for fluid oil lubrication

To ensure sufficient lubrication, the following minimum sizes for piston distributors to be used must be observed. The time interval between the individual lubrication pulses results from the relubrication quantity, the relubrication interval and the piston distributor size:

$$\text{Spacing of the lubrication pulses (km)} = \frac{\text{Piston distributor size (cm}^3\text{)}}{\text{Relubrication quantity (cm}^3\text{)}} \times \text{relubrication interval (km)}$$

8.14 Relubrication

⚠ Caution! Risk of damage to the linear guideways due to incorrect lubrication quantities.

Too little or excessive lubricant quantities/pressure can damage or destroy the product.

- ▶ Make sure relubrication is done regularly and in sufficient quantity!
- ▶ The specified work steps must be followed without fail in order to avoid damage to the product!

The lubrication intervals are very much dependent on the operating conditions (loads, speeds, acceleration) and the ambient conditions (temperature, fluids, contamination, etc.). Ambient influences such as high loads, vibrations, long travel distances and dirt can shorten the lubrication intervals. After the lubrication period has expired, add the lubricant quantities according to the information in section 8.13 by operating the grease gun once or by setting the central lubrication system accordingly.

Note
Check whether a film of lubricant is visible on the entire profile rail. If this is not the case, increase the amount of lubricant.

Note
If the long-term lubrication unit is empty and will not be refilled or replaced, the "grease lubrication" relubrication interval applies.

8.14.1 Relubrication intervals for grease lubrication

The relubrication intervals depend, among other things, on the P/C load ratio. Here P stands for the equivalent dynamic load and C for the dynamic load rating.

Fig. 8.21: Relubrication intervals with grease lubrication, one-sided and two-sided long-term lubrication unit (E2/EC) for HG, EG, CG, WE. The long-term lubrication unit (E2/EC) is not available for the WE series.

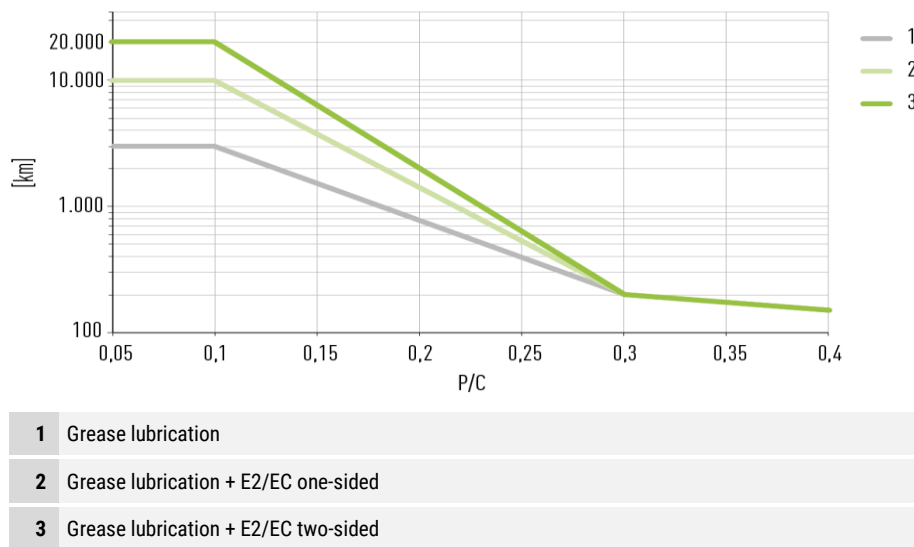

Fig. 8.22: Relubrication intervals with grease lubrication, one-sided and two-sided long-term lubrication unit (E2/EC) for QH, QE and QW. The long-term lubrication unit (E2/EC) is not available for the QW series.

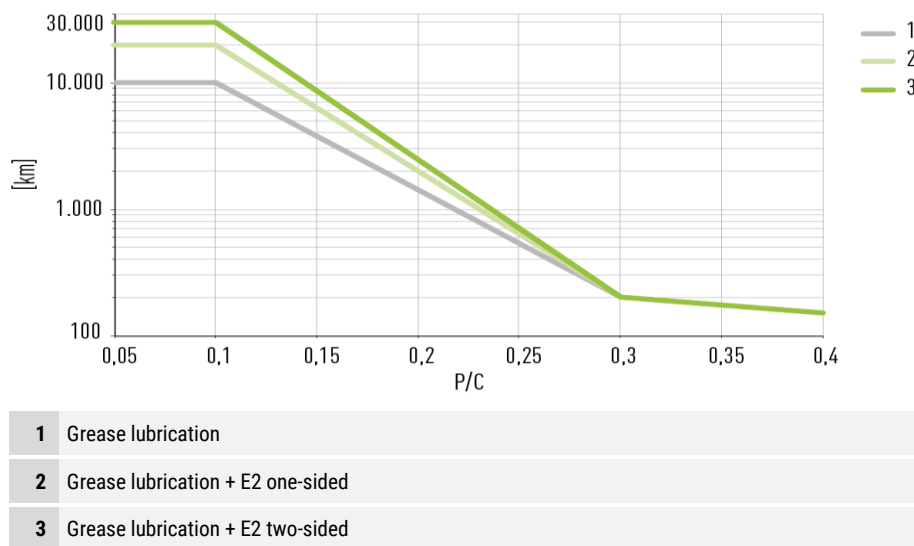

Fig. 8.23: Relubrication intervals with grease lubrication, one-sided and two-sided long-term lubrication unit (E2/EC) for UR and RG.

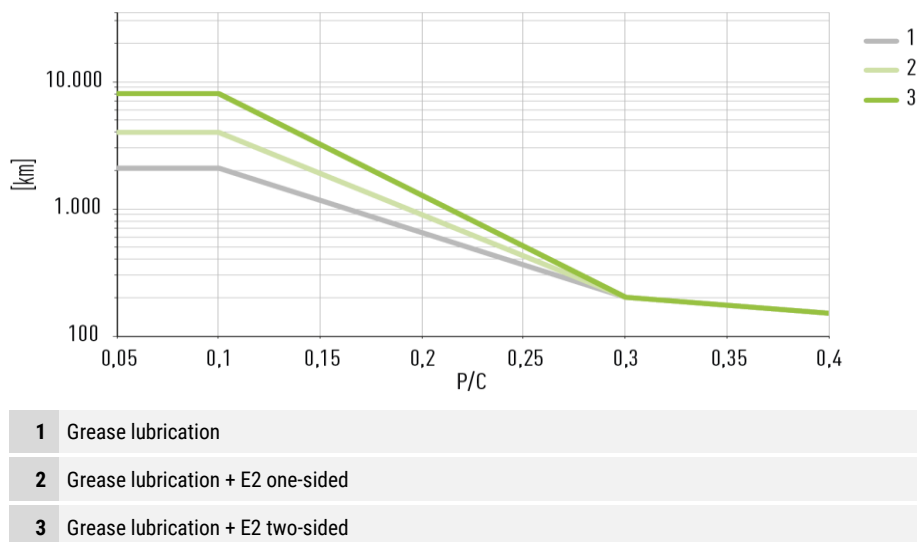

Fig. 8.24: Relubrication intervals with grease lubrication, one-sided and two-sided long-term lubrication unit (E2/EC) for QR. The long-term lubrication unit (E2/EC) is not available for the QR series.

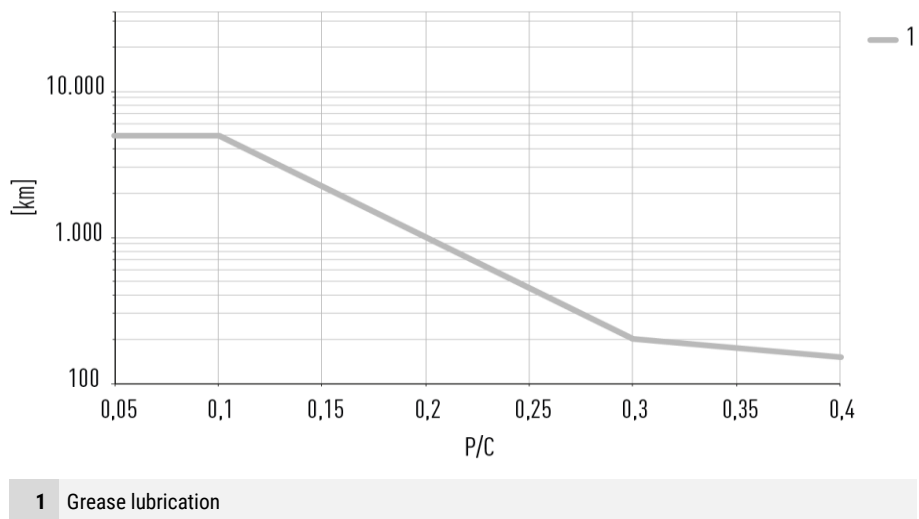
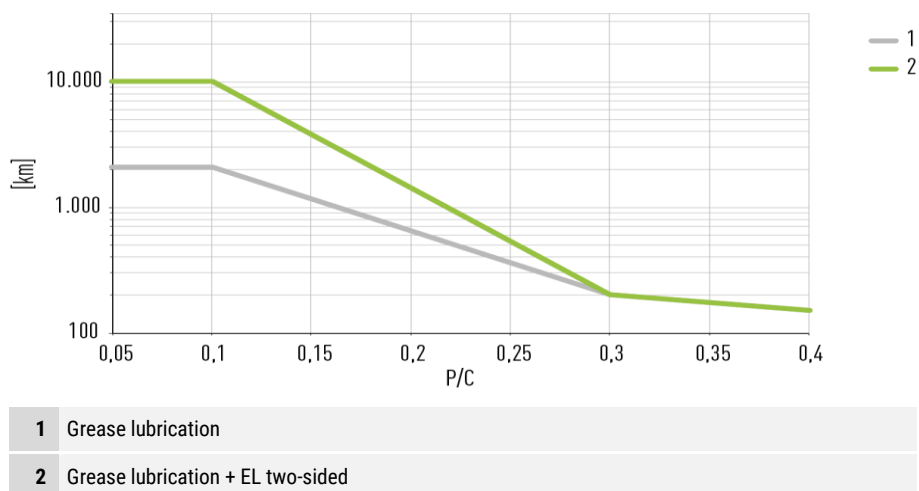

Fig. 8.25: Relubrication intervals with grease lubrication, one-sided and two-sided long-term lubrication unit (E2/EC/EL) for MG. The long-term lubrication unit (EL) for MG cannot be refilled. ISOFLEX TOPAS AK 50 is recommended for lubrication.



Note

Under the following conditions, the relubrication intervals may be shorter. Please consult HIWIN in these cases:
 $v > 3 \text{ m/s}$, $a > 30 \text{ m/s}^2$, media impact, temperatures $< 20 \text{ }^\circ\text{C}$ or $> 30 \text{ }^\circ\text{C}$, dirty environment, excess soil.

8.14.2 Relubrication intervals for fluid grease lubrication

The relubrication intervals with fluid grease lubrication are shortened by 25% compared the relubrication intervals with grease lubrication (see section [8.14.1](#)).

8.14.3 Relubrication intervals with oil lubrication

The relubrication intervals with oil lubrication are reduced to 50% of the relubrication intervals with grease lubrication (see section [8.14.1](#)).

9 Disposal

! **Caution!** Environmentally hazardous substances!

Environmentally hazardous substances, such as oils, can cause serious damage to the environment.

- ▶ Always clean contaminated components before disposal!
- ▶ Clarify proper disposal with disposal companies and, if necessary, with the responsible authorities!

Liquids	
Lubricants	Dispose of as hazardous waste in an environmentally-safe manner
Soiled cleaning cloths	Dispose of as hazardous waste in an environmentally-safe manner
Block	
Steel components	Sort by type before disposal
Plastic components	Dispose of as residual waste
Profile rails	
Steel components	Sort by type before disposal
Plastic cover caps	Dispose of as residual waste

10 Troubleshooting measures

Fault	Possible cause	Remedy
High running noise of the linear guideway during operation	Travel speed of the linear guideway too high	Checking the permissible travel speed (see section 12.1)
	Insufficient lubrication	Lubricate the linear guideway as specified by the lubrication instructions
Blocks require high displacement forces	Preload of the block on the profile rail too high	Inspection of the required preload of the block
	Insufficient lubrication	Lubricate the linear guideway as specified by the lubrication instructions
Block loses balls	The block is damaged or the seals on the block are damaged.	Contact HIWIN support.

11 Accessories

11.1 Long-term lubrication unit

11.1.1 Long-term lubrication unit E2 for HG/QH, EG/QE, RG series

The long-term lubrication unit can be mounted on one or both sides of the block. Long-term lubrication unit E2 consists of a lubrication unit [5] between the recirculation system [4] and the end seal [3], a connecting piece [2] and the replaceable oil cartridge [1]. Lubricant from the oil cartridge passes via the connecting piece to the lubrication unit, which then transfers the lubricant to the track of the profile rail.

Fig. 11.1: Exploded view of long-term lubrication unit E2 for HG, EG, RG series

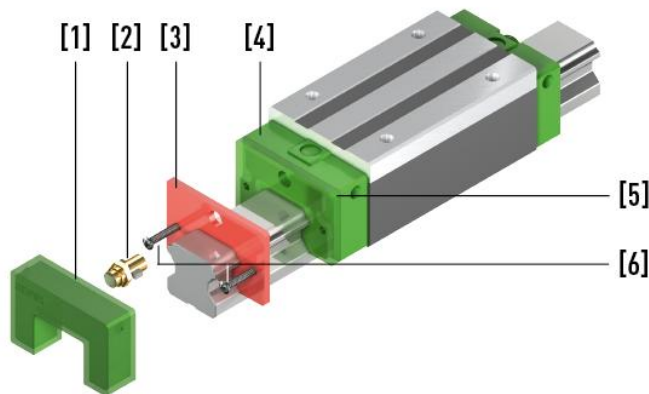

1	Oil tank
2	Connecting piece
3	End seal
4	Deflector
5	Long-term lubrication unit
6	Mounting bolts

11.1.1.1 Assembly

- If necessary, disassemble the existing grease nipple and the end seal.
- Place the long-term lubricating unit [5] on the block.
- Place the end seals(s) [3] before the long-term lubrication unit [5].
- Tighten the fastening screws [6].
- Mount the connecting piece [2].

Note

The screw size and the size of the connecting piece can vary depending on which type of dust protection is used.

- Push the oil cartridge [1] onto the long-term lubrication unit until it engages with an audible click.
- ✓ Long-term lubrication unit E2 is mounted.

11.1.2 Long-term lubrication unit EC for CG series

The long-term lubrication unit can be mounted on one or both sides of the block. Long-term lubrication unit EC for the CG series consists of a lubrication unit including oil cartridge [2] and an additional end seal [1]. The ball track is lubricated via the long-term lubrication unit.

Fig. 11.2: Exploded view of long-term lubrication unit EC for CG series

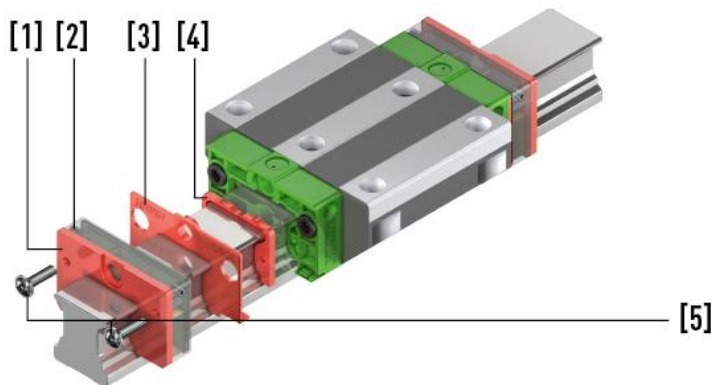

1	End seal
2	Long-term lubrication unit
3	Standard scraper
4	Standard end seal
5	Mounting bolts

11.1.2.1 Assembly

- Remove the standard end seal [4]. To do so, dismantle the existing grease nipple/lubrication plug screw and the standard scraper [3] if necessary.
- Place the standard scraper [3] on the block.
- Place the long-term lubricating unit [2] on the block.
- Place the end seal(s) [1] in front of the long-term lubrication unit [2].
- Tighten the fastening screws [5].

Note

The screw size and the size of the connecting piece can vary depending on which type of dust protection is used.

- ✓ Long-term lubrication unit EC is mounted.

11.1.3 Relubrication intervals

Note

The relubrication intervals or running performances can be found in chapter [8.14.1](#).

Note

You can either fill the long-term lubrication unit using an injector via the fill holes on the side or you can replace the whole component.

Note

The long-term lubrication unit (EL) for MG cannot be refilled.

Table 11.1: Oil quantity of the long-term lubrication unit

Model	Oil quantity [cm ³]
HG15E2/QH15E2	1.6
HG20E2/QH20E2	3.9
HG25E2/QH25E2	5.1
HG30E2/QH30E2	7.8
HG35E2/QH35E2	9.8
HG45E2/QH45E2	18.5
HG55E2	25.9
HG65E2	50.8
EG15E2/QE15E2	1.7
EG20E2/QE20E2	2.9
EG25E2/QE25E2	4.8
EG30E2/QE30E2	8.9
EG35E2/QE35E2	10.3
CG15EC	1.2
CG20EC	1.8
CG25EC	1.8
RG25E2	5.0
RG30E2	7.5
RG35E2	10.7
RG45E2	18.5
RG55E2	26.5
RG65E2	50.5
MGN07EL	0.05
MGN09EL	0.10
MGN12EL	0.19
MGW09EL	0.29
MGW12EL	0.33

E2/EL:

Standard oil:

Mobil SHC 636

Fully synthetic on hydrocarbon basis (PAO)

Viscosity class: ISO VG 680

Oils of the same classification and viscosity can be used as a substitute.

EC:

Standard oil:

Total Carter SH 680

Synthetic oil (PAO)

Viscosity class: ISO VG 680

11.2 Additional assembly and disassembly tool

Table 11.2: Assembly tool for pressing in steel or brass cover caps

Series/size	Article number
HG_15	5-002519
HG_20	5-000915
HG_25	5-000916
HG_30	5-000917
HG_35	5-000918
HG_45	5-000919
HG_55	5-000920
HG_65	5-000921
RG_20	12-000542
RG_25	12-000309
RG_30	12-000310
UR_35, RG_35	12-000311
UR_45, RG_45	12-000312
UR_55, RG_55	12-000313
RG_65	12-000314

Table 11.3: Assembly/disassembly tool for cover strip

Size (all series)	Article number
15	5-002557
20	5-002417
25	5-002416
30	5-002554
35	5-002555
45	5-002556

Table 11.4: Expanding mandrel

Size (all series)	Article number
15	5-002725
20	5-002726
25	5-002727
30	5-002728
35	5-002729
45	5-002730
55	5-002731
65	5-002732

12 Appendix

12.1 Maximum speeds and accelerations for HIWIN linear guideways

The following maximum speeds and accelerations are permissible for HIWIN linear guideways ¹⁾:

Table 12.1: Permissible maximum speeds and accelerations for HIWIN linear guideways

Model	Max. speed v_{max} [m/s]	Max. acceleration a_{max} [m/s ²]
QH, QE, QW	5	100
HG, EG, CG, WE, QR	5	80
MG	5	50
UR, RG, CRG	3	30

¹⁾ Depending on the respective application, higher values are possible, please consult HIWIN.

12.2 Assembly tolerances

Provided that the requirements for the accuracy of the mounting surface are met, the precision and rigidity of the linear guideways can also be achieved without any problems. To ensure fast assembly and smooth movement, HIWIN offers linear guideways with light preload (Z0) that compensate for deviations on the mounting surface over a wide range.

Note

If the displacement forces of the blocks increase sharply after assembly, there is most likely a distortion. In this case, be sure to check the mounting surfaces for contamination and burrs, as well as the permissible mounting tolerances.

12.2.1 Tolerance of parallelism of reference surface (P)

Fig. 12.1: Tolerance of parallelism of reference surface (P)

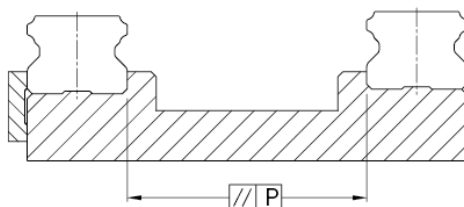

Table 12.2: Maximum tolerance for parallelism (P)

Series	Size	Preload class		
		Z0	ZA	ZB
HG/QH	15	25	18	–
	20	25	20	18
	25	30	22	20
	30	40	30	27
	35	50	35	30
	45	60	40	35
HG	55	70	50	45
	65	80	60	55
EG/QE EG/QE	15	25	18	–
	20	25	20	18
	25	30	22	20
	30	40	30	27
	35	50	35	30
	15	25	18	–
CG	15	9	5	4
	20	11	7	5
	25	12	8	6
	30	14	9	7
	35	15	11	8
	45	19	12	10
WE	15	20	15	9
	50	40	30	27
WE/QW	21	25	18	9
	27	25	20	13
	35	30	22	20

Unit: µm

Series	Size	Preload class		
		Z0	ZA	ZB
UR RG CRG	15	5	3	3
	20	8	6	4
	55	21	14	11
	65	27	18	14
UR RG/QR	25	9	7	5
	30	11	8	6
	35	14	10	7
	45	17	13	9

Unit: µm

Series	Size	Preload class		
		ZF	Z0	Z1
MG	02	2	2	2
	03	2	2	2
	05	2	2	2
	07	3	3	3
	09	4	4	3
	12	9	9	5
	15	10	10	6

Unit: µm

12.2.2 Tolerance of height of reference surface (S₁)

Fig. 12.2: Tolerance of height of reference surface (S₁)

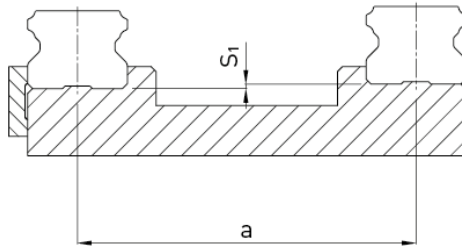

Applies to series HG/QH/EG/QE/WE/QW/MG

$$S_1 = a \times K$$

- S₁ Maximum height tolerance [mm]
- a Distance between rails [mm]
- K Coefficient of height tolerance

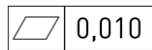

Accuracy requirement for all reference surfaces for rail fastening

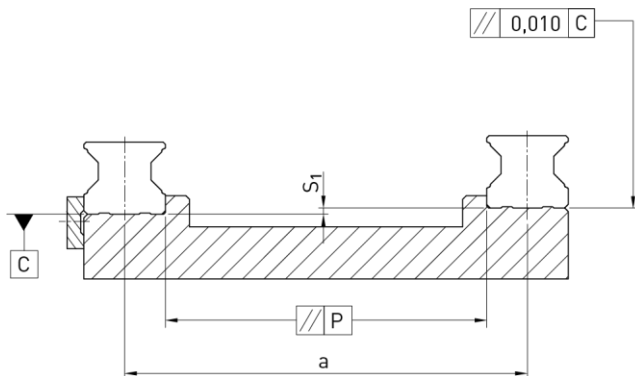

Applies to series CG/UR/RG/QR

$$S_1 = a \times K - T_H$$

- S₁ Maximum height tolerance [mm]
- a Distance between rails [mm]
- K Coefficient of height tolerance
- T_H Tolerance of height according to [Table 3.4](#)

Table 12.3: Coefficient of height tolerance (K)

Series	Size	Preload class		
		Z0	ZA	ZB
HG	55	6.0×10^{-4}	4.2×10^{-4}	3.4×10^{-4}
	65	7.0×10^{-4}	5.0×10^{-4}	4.0×10^{-4}
HG/QH	15	2.6×10^{-4}	1.7×10^{-4}	–
	20	2.6×10^{-4}	1.7×10^{-4}	1.0×10^{-4}
	25	2.6×10^{-4}	1.7×10^{-4}	1.4×10^{-4}
	30	3.4×10^{-4}	2.2×10^{-4}	1.8×10^{-4}
	35	4.2×10^{-4}	3.0×10^{-4}	2.4×10^{-4}
	45	5.0×10^{-4}	3.4×10^{-4}	2.8×10^{-4}
EG/QE	15	2.6×10^{-4}	1.7×10^{-4}	–
	20	2.6×10^{-4}	1.7×10^{-4}	1.0×10^{-4}
	25	2.6×10^{-4}	1.7×10^{-4}	1.4×10^{-4}
	30	3.4×10^{-4}	2.2×10^{-4}	1.8×10^{-4}
	35	4.2×10^{-4}	3.0×10^{-4}	2.4×10^{-4}
CG	15 – 45	2.8×10^{-4}	1.7×10^{-4}	1.2×10^{-4}
WE	15	1.3×10^{-4}	0.4×10^{-4}	–
	50	3.4×10^{-4}	2.2×10^{-4}	1.8×10^{-4}
WE/QW	21	2.6×10^{-4}	1.7×10^{-4}	0.9×10^{-4}
	27	2.6×10^{-4}	1.7×10^{-4}	0.9×10^{-4}
	35	2.6×10^{-4}	1.7×10^{-4}	1.4×10^{-4}
UR/RG	15 – 65	2.2×10^{-4}	1.7×10^{-4}	1.2×10^{-4}
QR	25 – 45	2.2×10^{-4}	1.7×10^{-4}	1.2×10^{-4}

Table 12.4: Coefficient of height tolerance (K) for MG series

Series	Size	Preload class		
		ZF	Z0	Z1
MG	05	0.4×10^{-4}	0.4×10^{-4}	0.04×10^{-4}
	07	0.5×10^{-4}	0.5×10^{-4}	0.06×10^{-4}
	09	0.7×10^{-4}	0.7×10^{-4}	0.12×10^{-4}
	12	1.0×10^{-4}	1.0×10^{-4}	0.24×10^{-4}
	15	1.2×10^{-4}	1.2×10^{-4}	0.40×10^{-4}

12.2.3 Height tolerance of the mounting surfaces of the blocks (S₂/S₃)

Fig. 12.3: Maximum height tolerance S₂

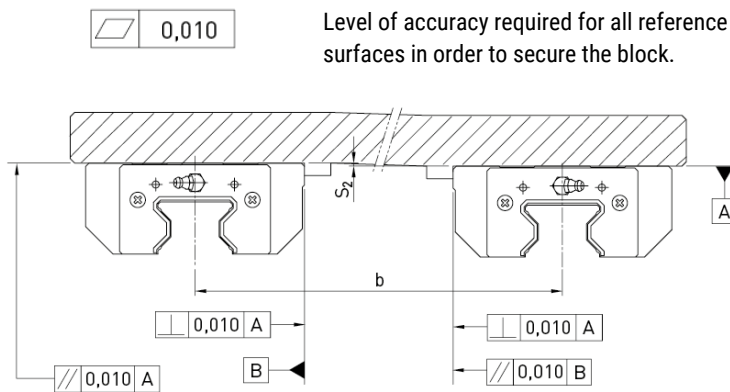
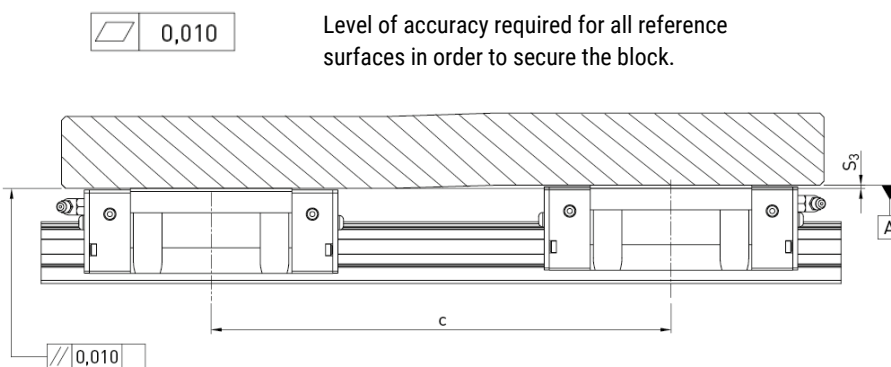

Fig. 12.4: Maximum height tolerance S₃



The height tolerance of the reference surface when two or more block are used in parallel (S₂/S₃)

$S_2 = b \times K$

- S₂ Maximum height tolerance [mm]
- b Distance between blocks [mm]
- K Coefficient of height tolerance

$S_3 = c \times K$

- S₃ Maximum height tolerance [mm]
- c Distance between blocks [mm]
- K Coefficient of height tolerance

Table 12.5: Coefficient of height tolerance (K) of series CG

Series	Size	Load type	
		CG_C	CG_H
CG	15 – 45	4.2×10^{-5}	3.0×10^{-5}

Table 12.6: Coefficient of height tolerance (K) of series CG

Series	Size	Load type	
		UR/RG_C/QR_C	UR/RG_H/QR_H
UR/RG	15 – 65	4.2×10^{-5}	3.0×10^{-5}
QR	25 – 45	4.2×10^{-5}	3.0×10^{-5}

12.2.4 Requirement for the mounting surface – MG series

The following requirements for the mounting surface must also be adhered to in the case of the MG series.

Note

The values in the table apply to preload classes ZF and Z0. For Z1 or if more than one rail is mounted on the same surface, the table values must be at least halved.

Table 12.7: Requirements for the mounting surface – MG series

Series/Size	Required flatness of the mounting surface
MG_05	0.015/200
MG_07	0.025/200
MG_09	0.035/200
MG_12	0.050/200
MG_15	0.060/200

Unit: mm

12.2.5 Shoulder heights and edge roundings

Inaccurate shoulder heights and edge roundings of mounting surfaces impair accuracy and may conflict with the block or rail profile. The following shoulder heights and edge profiles must be observed to avoid assembly problems.

12.2.5.1 HG and QH series

Fig. 12.5: Shoulder height and fillets – HG/QH series

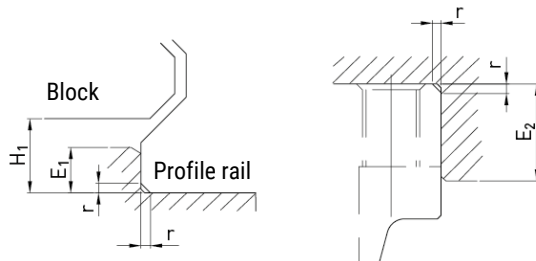

Table 12.8: Shoulder heights and edge roundings

Series/Size	Max. radius of edges r	Shoulder height of the reference side of rail E ₁	Shoulder height of the reference side of block E ₂	Clearance height under block H ₁
HG_15	0.5	3.0	4.0	4.3
QH_15	0.5	3.0	4.0	4.0
HG/QH_20	0.5	3.5	5.0	4.6
HG/QH_25	1.0	5.0	5.0	5.5
HG/QH_30	1.0	5.0	5.0	6.0
HG/QH_35	1.0	6.0	6.0	7.5
HG/QH_45	1.0	8.0	8.0	9.5
HG_55	1.5	10.0	10.0	13.0
HG_65	1.5	10.0	10.0	15.0

Unit: mm

12.2.5.2 EG and QE series

Fig. 12.6: Shoulder height and fillets – EG/QE series

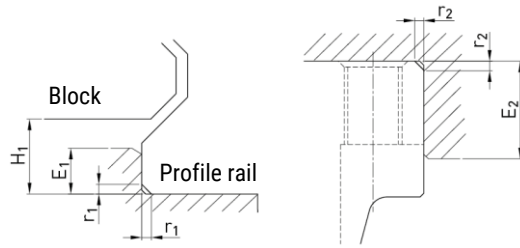

Table 12.9: Shoulder heights and fillets – EG/QE series

Series/ Size	Max. radius of edges r ₁	Max. radius of edges r ₂	Shoulder height of the reference side of rail E ₁	Shoulder height of the reference side of block E ₂	Clearance height under block H ₁
EG/QE_15	0.5	0.5	2.7	5.0	4.5
EG/QE_20	0.5	0.5	5.0	7.0	6.0
EG/QE_25	1.0	1.0	5.0	7.5	7.0
EG/QE_30	1.0	1.0	7.0	7.0	10.0
EG_35	1.0	1.0	7.5	9.5	11.0
QE_35	1.0	1.5	7.5	9.5	11.0

Unit: mm

12.2.5.3 CG series

Fig. 12.7: Shoulder height and fillets – CG series

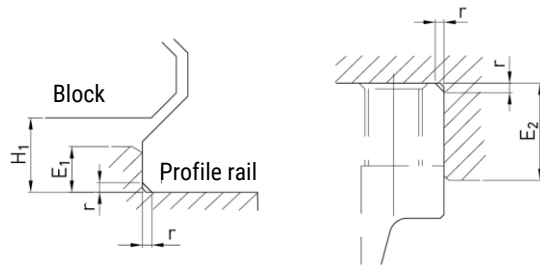

Table 12.10: Shoulder heights and fillets – CG series

Series/ Size	Max. radius of edges r	Shoulder height of the reference side of rail E ₁	Shoulder height of the reference side of block E ₂	Clearance height under block H ₁
CG_15	0.5	3.0	4.0	4.3
CG_20	0.5	3.5	5.0	4.6
CG_25	1.0	5.0	5.0	6.1
CG_30	1.0	5.0	5.0	7.0
CG_35	1.0	6.0	6.0	7.6
CG_45	1.0	8.0	8.0	9.5

Unit: mm

12.2.5.4 WE and QW series

Fig. 12.8: Shoulder height and fillets – WE/QW series

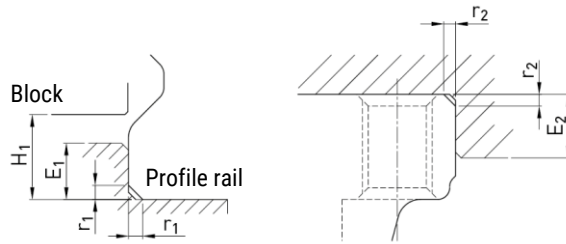

Table 12.11: Shoulder heights and fillets – WE/QW series

Series/ Size	Max. radius of edges r_1	Max. radius of edges r_2	Shoulder height of the reference side of rail E_1	Shoulder height of the reference side of block E_2	Clearance height under block H_1
WE_17	0.4	0.4	2.0	4.0	2.5
WE/QW_21	0.4	0.4	2.5	5.0	3.0
WE/QW_27	0.5	0.5	3.0	7.0	4.0
WE/QW_35	0.5	0.5	3.5	10.0	4.0
WE_50	0.8	0.8	6.0	10.0	7.5

Unit: mm

12.2.5.5 MG series

Fig. 12.9: Shoulder height and fillets – MG series

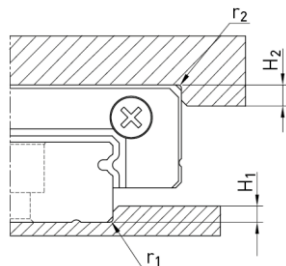

Table 12.12: Shoulder heights and fillets – MG series

Series/ Size	Max. radius of edges r_1	Max. radius of edges r_2	Shoulder height of H_1	Shoulder height of H_2
MGN02	0.1	0.2	0.5	1.5
MGN03	0.1	0.2	0.6	1.5
MGN05	0.1	0.2	1.2	2.0
MGN07	0.2	0.2	1.2	3.0
MGN09	0.2	0.3	1.7	3.0
MGN12	0.3	0.4	1.7	4.0
MGN15	0.5	0.5	2.5	5.0
MGW05	0.1	0.2	1.2	2.0
MGW07	0.2	0.2	1.7	3.0
MGW09	0.3	0.3	2.5	3.0
MGW12	0.4	0.4	3.0	4.0
MGW15	0.4	0.8	3.0	5.0

Unit: mm

12.2.5.6 UR, RG and QR series

Fig. 12.10: Shoulder height and fillets – UR/RG/QR series

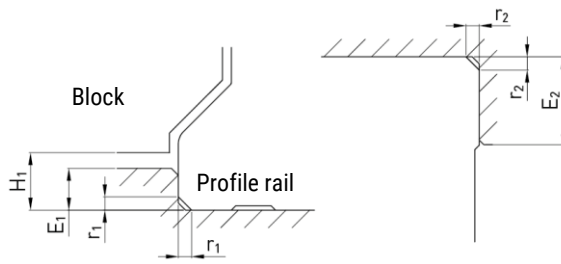

Table 12.13: Shoulder heights and fillets – UR/RG/QR series

Series/ Size	Max. radius of edges r_1	Max. radius of edges r_2	Shoulder height of the reference side of rail E_1	Shoulder height of the reference side of block E_2	Clearance height under block H_1
UR_35	1,0	1,0	6,0	6,0	7,0
UR_45	1,0	1,0	7,0	8,0	8,0
UR_55	1,5	1,5	9,0	10,0	10,0
RG_15	0,5	0,5	3,0	4,0	4,0
RG_20	0,5	0,5	3,5	5,0	5,0
RG/QR_25	1,0	1,0	5,0	5,0	5,5
RG/QR_30	1,0	1,0	5,0	5,0	6,0
RG/QR_35	1,0	1,0	6,0	6,0	6,5
RG/QR_45	1,0	1,0	7,0	8,0	8,0
RG_55	1,5	1,5	9,0	10,0	10,0
RG_65	1,5	1,5	10,0	10,0	12,0

Unit: mm

12.3 Technical data of block

12.3.1 Dimensions of the HG/QH blocks

HGH/QHH

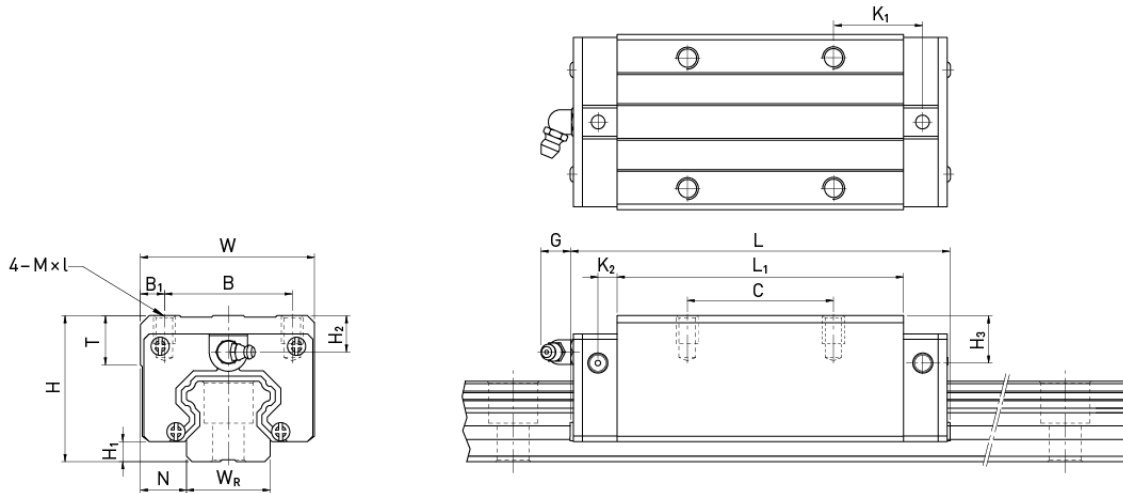

Dimensions of the block

Series/ Size	Installation dimensions [mm]			Dimensions of the block [mm]													Load ratings [N]		Weight (kg)
	H	H ₁	N	W	B	B ₁	C	L ₁	L	K ₁	K ₂	G	M × l	T	H ₂	H ₃	C _{dyn}	C ₀	
HGH15CA	28	4.3	9.5	34	26	4.0	26	39.4	61.4	10.00	4.85	5.3	M4 × 5	6.0	7.95	7.7	11,380	16,970	0.18
QHH15CA	28	4.0	9.5	34	26	4.0	26	39.4	61.4	10.00	5.00	5.3	M4 × 5	6.0	7.95	8.2	13,880	14,360	0.18
HGH20CA	30	4.6	12.0	44	32	6.0	36	50.5	77.5	12.25	6.00	12.0	M5 × 6	8.0	6.00	6.0	17,750	27,760	0.30
HGH20HA							50	65.2	92.2	12.60							21,180	35,900	0.39
QHH20CA	30	4.6	12.0	44	32	6.0	36	50.5	76.7	11.75	6.00	12.0	M5 × 6	8.0	6.00	6.0	23,080	25,630	0.29
QHH20HA							50	65.2	91.4	12.10							27,530	31,670	0.38
HGH25CA	40	5.5	12.5	48	35	6.5	35	58.0	84.0	15.70	6.00	12.0	M6 × 8	8.0	10.00	9.0	26,480	36,490	0.51
HGH25HA							50	78.6	104.6	18.50							32,750	49,440	0.69
QHH25CA	40	5.5	12.5	48	35	6.5	35	58.0	83.4	15.70	6.00	12.0	M6 × 8	8.0	10.00	9.0	31,780	33,680	0.50
QHH25HA							50	78.6	104.0	18.50							39,300	43,620	0.68
HGH30CA	45	6.0	16.0	60	40	10.0	40	70.0	97.4 ¹⁾	20.25	6.00	12.0	M8 × 10	8.5	9.50	13.8	38,740	52,190	0.88
HGH30HA							60	93.0	120.4 ²⁾	21.75							47,270	69,160	1.16
QHH30CA	45	6.0	16.0	60	40	10.0	40	70.0	97.4	19.50	6.25	12.0	M8 × 10	8.5	9.50	9.0	46,490	48,170	0.87
QHH30HA							60	93.0	120.4	21.75							56,720	65,090	1.15
HGH35CA	55	7.5	18.0	70	50	10.0	50	80.0	112.4	20.60	7.00	12.0	M8 × 12	10.2	16.00	19.6	49,520	69,160	1.45
HGH35HA							72	105.8	138.2	22.50							60,210	91,630	1.92
QHH35CA	55	7.5	18.0	70	50	10.0	50	80.0	113.6	19.00	7.50	12.0	M8 × 12	10.2	15.50	13.5	60,520	63,840	1.44
QHH35HA							72	105.8	139.4	20.90							73,590	86,240	1.90
HGH45CA	70	9.5	20.5	86	60	13.0	60	97.0	139.4	23.00	10.00	12.9	M10 × 17	16.0	18.50	30.5	77,570	102,710	2.73
HGH45HA							80	128.8	171.2	28.90							94,540	136,460	3.61

Dimensions of the block																			
QHH45CA	70	9.2	20.5	86	60	13.0	60	97.0	139.4	23.00	10.00	12.9	M10 × 17	16.0	18.50	20.0	89,210	94,810	2.72
QHH45HA							80	128.8	171.2	29.09							108,720	128,430	3.59
HGH55CA	80	13.0	23.5	100	75	12.5	75	117.7	166.7	27.35	11.00	12.9	M12 × 18	17.5	22.00	29.0	114,440	148,330	4.17
HGH55HA							95	155.8	204.8	36.40							139,350	196,200	5.49
HGH65CA	90	15.0	31.5	126	76	25.0	70	144.2	200.2	43.10	14.00	12.9	M16 × 20	25.0	15.00	15.0	163,630	215,330	7.00
HGH65HA							120	203.6	259.6	47.80							208,360	303,130	9.82

1) 98.8 for type SE
 2) 121.8 for type SE

HGL

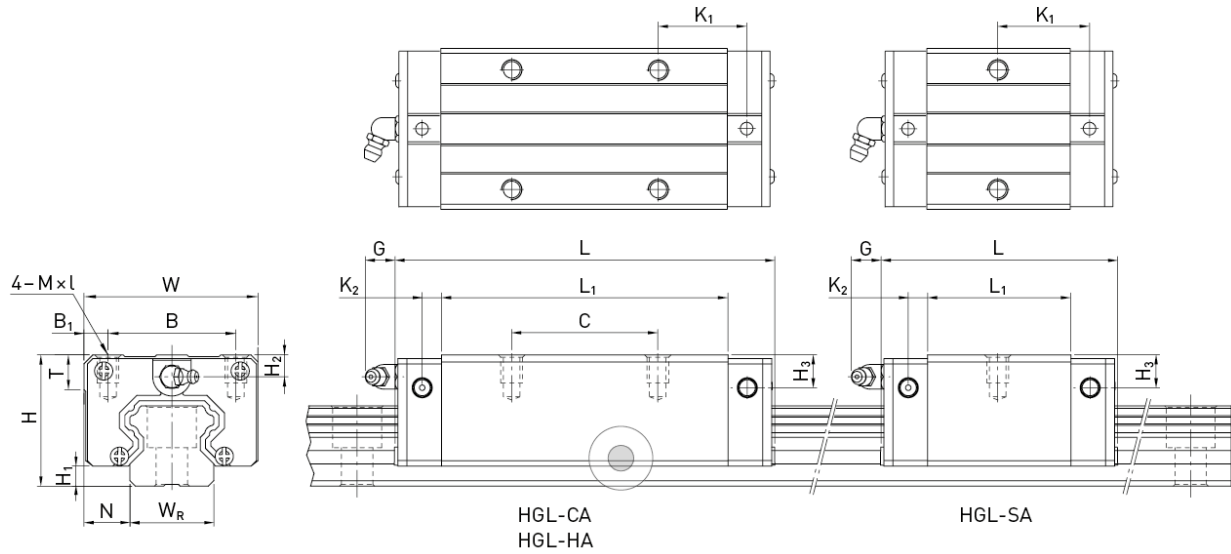

Dimensions of the block																					
Series/ Size	Installation dimensions [mm]			Dimensions of the block [mm]													Load ratings [N]		Weight [kg]		
	H	H ₁	N	W	B	B ₁	C	L ₁	L	K ₁	K ₂	G	M × l	T	H ₂	H ₃	C _{dyn}	C ₀			
HGL15CA	24	4.3	9.5	34	26	4.0	26	39.4	61.4	10.00	4.85	5.3	M4 × 4	6.0	3.95	3.7	11,380	16,970	0.14		
HGL25SA	36	5.5	12.5	48	35	6.5	-	38.2	64.2	23.20	6.00	12.0	M6 × 6	8.0	6.00	5.0	18,650	24,290	0.32		
HGL25CA							35	58.0	84.0	15.70									26,480	36,490	0.42
HGL25HA							50	78.6	104.6	18.50									32,750	49,440	0.57
HGL30CA	42	6.0	16.0	60	40	10.0	40	70.0	97.4 ¹⁾	20.25	6.00	12.0	M8 × 10	8.5	6.50	10.8	38,740	52,190	0.78		
HGL30HA							60	93.0	120.4 ²⁾	21.75									47,270	69,160	1.03
HGL35CA	46	7.5	18.0	70	50	10.0	50	80.0	112.4	20.60	7.00	12.0	M8 × 12	10.2	9.00	12.6	49,520	69,160	1.14		
HGL35HA							72	105.8	138.2	22.50									60,210	91,630	1.52
HGL45CA	60	9.5	20.5	86	60	13.0	60	97.0	139.4	23.00	10.00	12.9	M10 × 17	16.0	8.50	20.5	77,570	102,710	2.08		
HGL45HA							80	128.8	171.2	28.90									94,540	136,460	2.75
HGL55CA	70	13.0	23.5	100	75	12.5	75	117.7	166.7	27.35	11.00	12.9	M12 × 18	17.5	12.00	19.0	114,440	148,330	3.25		
HGL55HA							95	155.8	204.8	36.40									139,350	196,200	4.27

1) 98.8 for type SE
 2) 121.8 for type SE

HGW/QHW

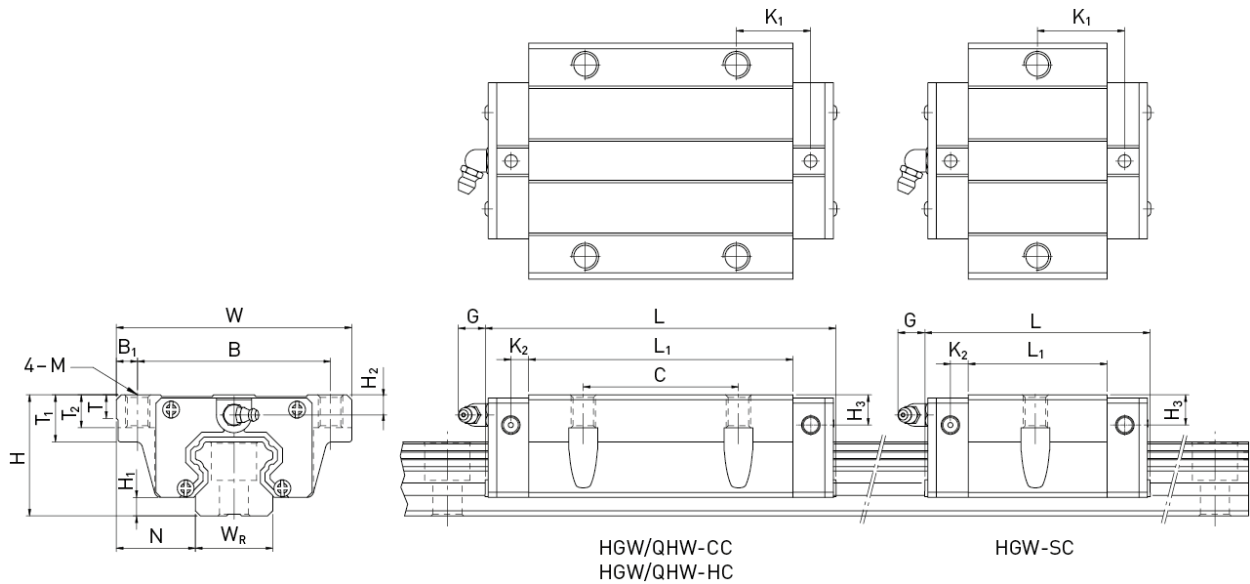

Dimensions of the block																								
Series/ Size	Installation dimensions [mm]			Dimensions of the block [mm]															Load ratings [N]		Weight t (kg)			
	H	H ₁	N	W	B	B ₁	C	L ₁	L	K ₁	K ₂	M	G	T	T ₁	T ₂	H ₂	H ₃	C _{dyn}	C ₀				
HGW15CC	24	4.3	16.0	47	38	4.5	30	39.4	61.4	8.00	4.85	M5	5.3	6.0	8.9	7.0	3.95	3.7	11,380	16,970	0.17			
QHW15CC	24	4.0	16.0	47	38	4.5	30	39.4	61.4	8.00	5.00	M5	5.3	6.0	8.9	7.0	3.95	4.2	13,880	14,360	0.17			
HGW20SC	30	4.6	21.5	63	53	5.0	-	29.5	54.3	19.65	6.00	M6	12.0	8.0	10.0	9.5	6.00	6.0	12,190	16,110	0.28			
HGW20CC							40	50.5	77.5	10.25												17,750	27,760	0.40
HGW20HC							40	65.2	92.2	17.60												21,180	35,900	0.52
QHW20CC	30	4.6	21.5	63	53	5.0	40	50.5	76.7	9.75	6.00	M6	12.0	8.0	10.0	9.5	6.00	6.0	23,080	25,630	0.40			
QHW20HC							40	65.2	91.4	17.10												27,530	31,670	0.52
HGW25SC	36	5.5	23.5	70	57	6.5	-	38.2	64.2	23.20	6.00	M8	12.0	8.0	14.0	10.0	6.00	5.0	18,650	24,290	0.42			
HGW25CC							45	58.0	84.0	10.70												26,480	36,490	0.59
HGW25HC							45	78.6	104.6	21.00												32,750	49,440	0.80
QHW25CC	36	5.5	23.5	70	57	6.5	45	58.0	83.4	10.70	6.00	M8	12.0	8.0	14.0	10.0	6.00	5.0	31,780	33,680	0.59			
QHW25HC							45	78.6	104.0	21.00												39,300	43,620	0.80
HGW30CC	42	6.0	31.0	90	72	9.0	52	70.0	97.4 ¹⁾	14.25	6.00	M10	12.0	8.5	16.0	10.0	6.50	10.8	38,740	52,190	1.09			
HGW30HC							52	93.0	120.4 ²⁾	25.75												47,270	69,160	1.44
QHW30CC	42	6.0	31.0	90	72	9.0	52	70.0	97.4	13.50	6.25	M10	12.0	8.5	16.0	10.0	6.50	6.0	46,490	48,170	1.09			
QHW30HC							52	93.0	120.4	25.75												56,720	65,090	1.44
HGW35CC	48	7.5	33.0	100	82	9.0	62	80.0	112.4	14.60	7.00	M10	12.0	10.1	18.0	13.0	9.00	12.6	49,520	69,160	1.56			
HGW35HC							62	105.8	138.2	27.50												60,210	91,630	2.06
QHW35CC	48	7.5	33.0	100	82	9.0	62	80.0	113.6	13.00	7.50	M10	12.0	10.1	18.0	13.0	8.50	6.5	60,520	63,840	1.56			
QHW35HC							62	105.8	139.4	25.90												73,590	86,240	2.06
HGW45CC	60	9.5	37.5	120	100	10.0	80	97.0	139.4	13.00	10.00	M12	12.9	15.1	22.0	15.0	8.50	20.5	77,570	102,710	2.79			
HGW45HC							80	128.8	171.2	28.90												94,540	136,460	3.69
QHW45CC	60	9.2	37.5	120	100	10.0	80	97.0	139.4	13.00	10.00	M12	12.9	15.1	22.0	15.0	8.50	10.0	89,210	94,810	2.79			
QHW45HC							80	128.8	171.2	28.90												108,720	128,430	3.69

Dimensions of the block

HGW55CC	70	13.0	43.5	140	116	12.0	95	117.7	166.7	17.35	11.00	M14	12.9	17.5	26.5	17.0	12.00	19.0	114,440	148,330	4.52
HGW55HC								155.8	204.8	36.40									139,350	196,200	5.96
HGW65CC	90	15.0	53.5	170	142	14.0	110	144.2	200.2	23.10	14.00	M16	12.9	25.0	37.5	23.0	15.00	15.0	163,630	215,330	9.17
HGW65HC								203.6	259.6	52.80									208,360	303,130	12.89

¹⁾ 98.8 for type SE

²⁾ 121.8 for type SE

12.3.2 Dimensions of the CG blocks

CGH

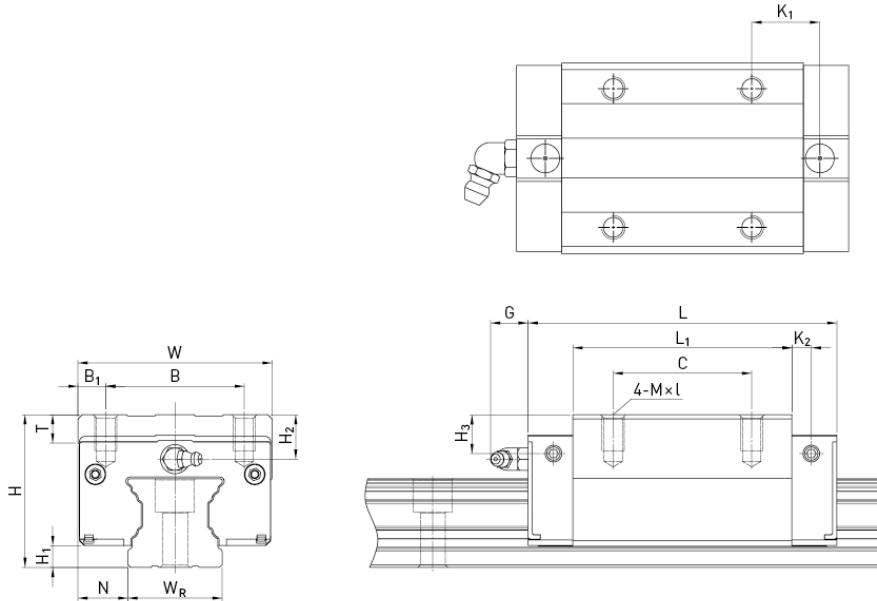

Dimensions of the block

Series/ Size	Installation dimensions [mm]			Dimensions of the block [mm]													Load ratings [N]		Weight (kg)
	H	H ₁	N	W	B	B ₁	C	L ₁	L	K ₁	K ₂	G	M × l	T	H ₂	H ₃	C _{dyn}	C ₀	
CGH15CA	28	4.1	9.5	34	26	4.0	26	39.6	58.2	10.8	4.25	6.0	M4 × 6	6.0	7.8	7.8	14,700	19,520	0.15
CGH20CA	30	4.6	12.0	44	32	6.0	36	52.5	74.9	12.45	5.50	6.0	M5 × 6	8.0	3.7	3.5	23,700	30,510	0.25
CGH20HA							50	68.5	90.9	13.45							28,600	39,900	0.33
CGH25CA	40	6.1	12.5	48	35	6.5	35	61.0	84.0	17.4	5.00	12.0	M6 × 8	8.0	10.0	9.5	34,960	43,940	0.46
CGH25HA							50	78.4	101.4	18.6							40,500	54,080	0.59
CGH30CA	45	7.0	16.0	60	40	10.0	40	69.0	97.4	19.75	8.70	12.0	M8 × 10	9.5	9.7	10.0	46,000	55,190	0.71
CGH30HA							60	91.5	119.9	21							58,590	78,180	0.94
CGH35CA	55	7.6	18.0	70	50	10.0	50	79.0	111.4	22.6	7.00	12.0	M8 × 13	10.2	16.0	14.0	61,170	79,300	1.24
CGH35HA							72	103.4	135.8	23.8							77,900	112,340	1.62
CGH45CA	70	9.7	20.5	86	60	13.0	60	97.2	137.6	23	8.70	12.9	M10 × 17	16.0	18.5	18.2	98,430	112,660	2.38
CGH45HA							80	133.6	174.0	31.2							125,580	159,600	3.01

CGL

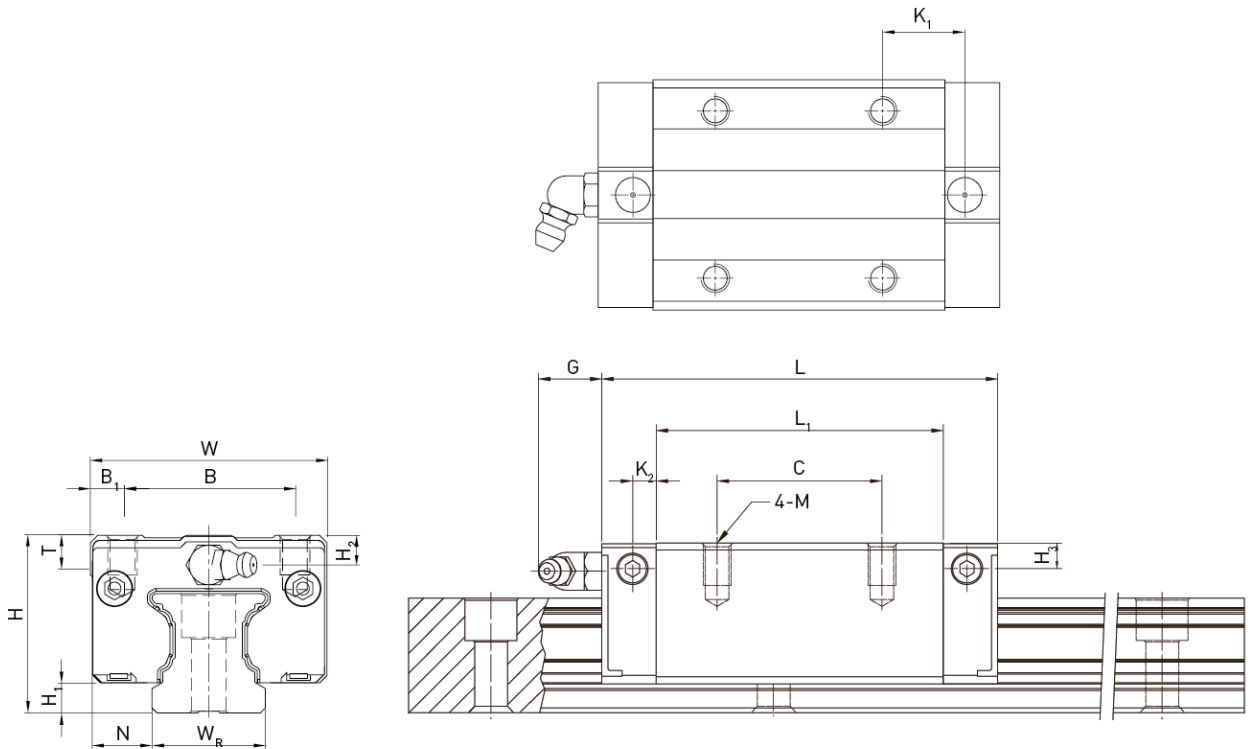

Dimensions of the block																				
Series/ Size	Installation dimensions [mm]			Dimensions of the block [mm]														Load ratings [N]		Weight (kg)
	H	H ₁	N	W	B	B ₁	C	L ₁	L	K ₁	K ₂	G	M × l	T	H ₂	H ₃	C _{dyn}	C ₀		
CGL15CA	24	4.1	9.5	34	26	4.0	26	39.6	58.2	10.8	4.25	6.0	M4 × 6	6.0	3.8	3.8	14,700	19,520	0.11	
CGL25CA	36	6.1	12.5	48	35	6.5	35	61.0	84.0	17.4	5.00	12.0	M6 × 8	8.0	6.0	5.5	34,960	43,940	0.37	
CGL25HA							50	78.4	101.4	18.6	40,500						54,080	0.47		
CGL30CA	42	7.0	16.0	60	40	10.0	40	69.0	97.4	19.75	8.70	12.0	M8 × 10	9.5	6.7	7.0	46,000	55,190	0.61	
CGL30HA							60	91.5	119.9	21.0	58,590						78,180	0.82		
CGL35CA	48	7.6	18.0	70	50	10.0	50	79.0	111.4	22.6	7.00	12.0	M8 × 13	10.2	9.0	7.0	61,170	79,300	0.93	
CGL35HA							72	103.4	135.8	23.8	77,900						112,340	1.22		
CGL45CA	60	9.7	20.5	86	60	13.0	60	97.2	137.6	23.0	8.70	12.9	M10 × 17	16.0	8.5	8.1	98,430	112,660	1.72	
CGL45HA							80	133.6	174.0	31.2	125,580						159,600	2.39		

CGW

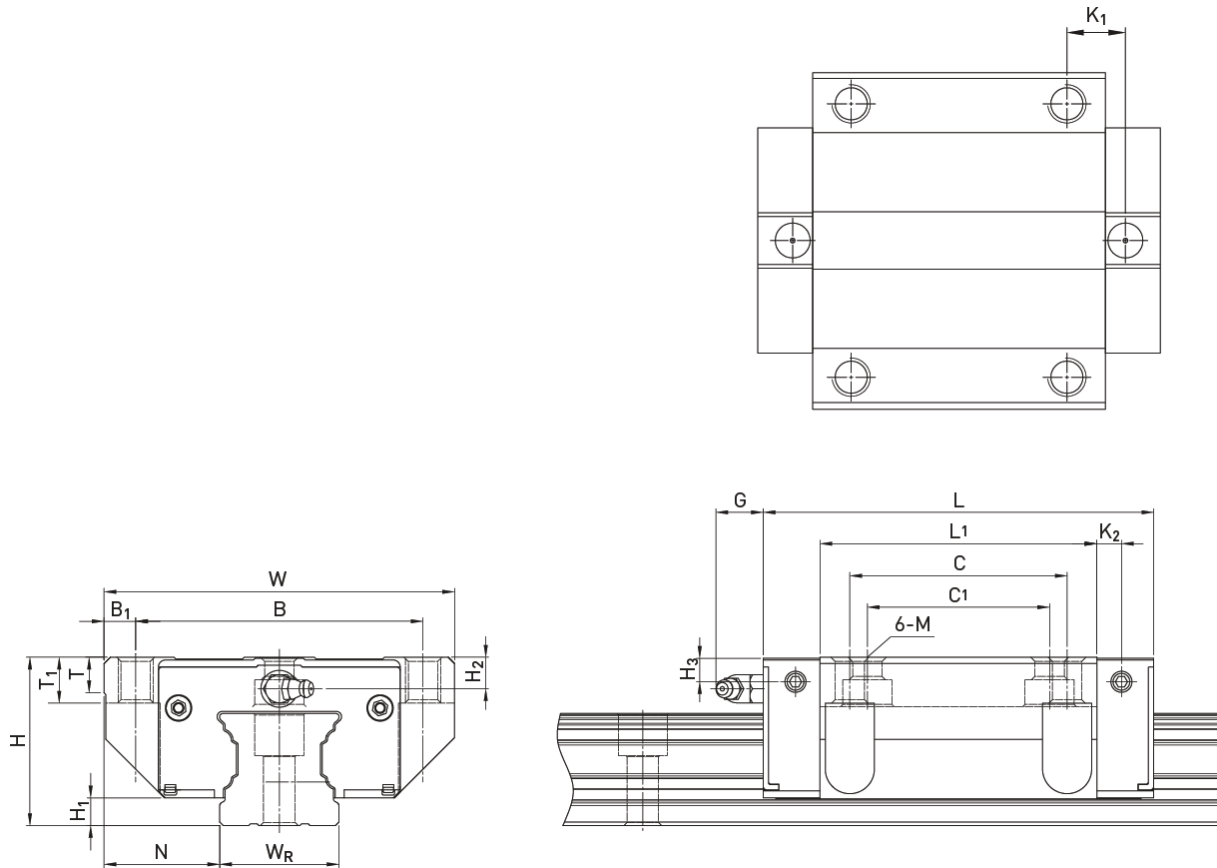

Dimensions of the block																						
Series/ Size	Installation dimensions [mm]			Dimensions of the block [mm]															Load ratings [N]		Weight (kg)	
	H	H ₁	N	W	B	B ₁	C	C ₁	L ₁	L	K ₁	K ₂	G	M	T	T ₁	H ₂	H ₃	C _{dyn}	C ₀		
CGW15CC	24	4.1	16.0	47	38	4.5	30	26	39.6	58.2	8.8	4.25	6.0	M5	6.0	6.5	3.8	3.8	14,700	19,520	0.14	
CGW20CC	30	4.6	21.5	63	53	5.0	40	35	52.5	74.9	10.45	5.50	6.0	M6	6.5	7.7	3.7	3.5	23,700	30,510	0.36	
CGW20HC									68.5	90.9	18.45	28,600							39,900	0.47		
CGW25CC	36	6.1	23.5	70	57	6.5	45	40	61.0	84.0	12.4	5.00	12.0	M8	7.0	9.3	6.0	5.5	34,960	43,940	0.53	
CGW25HC									78.4	101.4	21.1	40,500							54,080	0.68		
CGW30CC	42	7.0	31.0	90	72	9.0	52	44	69.0	97.4	13.75	8.70	12.0	M10	10.5	12.0	6.7	7.0	46,000	55,190	0.90	
CGW30HC									91.5	119.9	25.0	58,590							78,180	1.19		
CGW35CC	48	7.6	33.0	100	82	9.0	62	52	79.0	111.4	16.6	7.00	12.0	M10	10.1	13.1	9.0	7.0	61,170	79,300	1.37	
CGW35HC									103.4	135.8	28.8	77,900							112,340	1.79		
CGW45CC	60	9.7	37.5	120	100	10.0	80	60	97.2	137.6	13.0	8.70	12.9	M12	15.1	15.0	8.5	8.1	98,430	112,660	2.45	
CGW45HC									133.6	174.0	31.2	125,580							159,600	3.00		

12.3.3 Dimensions of the EG/QE blocks

EGH/QEH

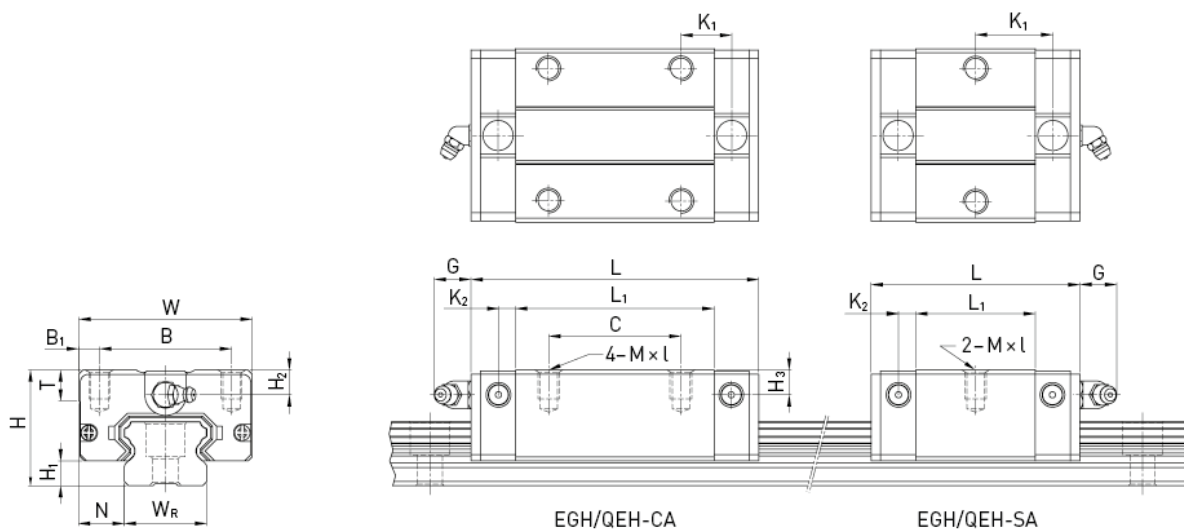

Dimensions of the block																				
Series/ Size	Installation dimensions [mm]			Dimensions of the block [mm]													Load ratings [N]		Weight (kg)	
	H	H ₁	N	W	B	B ₁	C	L ₁	L	K ₁	K ₂	G	M × l	T	H ₂	H ₃	C _{dyn}	C ₀		
EGH15SA	24	4.5	9.5	34	26	4.0	-	23.1	40.1	14.80	3.50	5.7	M4 × 6	6.0	5.5	6.0	5,350	9,400	0.09	
EGH15CA							26	39.8	56.8	10.15							7,830	16,190	0.15	
QEH15SA	24	4.0	9.5	34	26	4.0	-	23.1	40.1	14.80	3.50	5.7	M4 × 6	6.0	5.5	6.0	8,560	8,790	0.09	
QEH15CA							26	39.8	56.8	10.15							12,530	15,280	0.15	
EGH20SA	28	6.0	11.0	42	32	5.0	-	29.0	50.0	18.75	4.15	12.0	M5 × 7	7.5	6.0	6.0	7,230	12,740	0.15	
EGH20CA							32	48.1	69.1	12.30							10,310	21,130	0.24	
QEH20SA	28	6.0	11.0	42	32	5.0	-	29.0	50.0	18.75	4.15	12.0	M5 × 7	7.5	6.0	6.5	11,570	12,180	0.15	
QEH20CA							32	48.1	69.1	12.30							16,500	20,210	0.23	
EGH25SA	33	7.0	12.5	48	35	6.5	-	35.5	59.1	21.90	4.55	12.0	M6 × 9	8.0	8.0	8.0	11,400	19,500	0.25	
EGH25CA							35	59.0	82.6	16.15							16,270	32,400	0.41	
QEH25SA	33	6.2	12.5	48	35	6.5	-	35.5	60.1	21.90	5.00	12.0	M6 × 9	8.0	8.0	8.0	18,240	18,900	0.24	
QEH25CA							35	59.0	83.6	16.15							26,030	31,490	0.40	
EGH30SA	42	10.0	16.0	60	40	10.0	-	41.5	69.5	26.75	6.00	12.0	M8 × 12	9.0	8.0	9.0	16,420	28,100	0.45	
EGH30CA							40	70.1	98.1	21.05							23,700	47,460	0.76	
QEH30SA	42	10.0	16.0	60	40	10.0	-	41.5	67.5	25.75	6.00	12.0	M8 × 12	9.0	8.0	9.0	26,270	27,820	0.44	
QEH30CA							40	70.1	96.1	20.05							37,920	46,630	0.75	
EGH35SA	48	11.0	18.0	70	50	10.0	-	45.0	75.0	28.50	7.00	12.0	M8 × 12	10.0	8.5	8.5	22,660	37,380	0.74	
EGH35CA							50	78.0	108.0	20.00							33,350	64,840	1.10	
QEH35SA	48	11.0	18.0	70	50	10.0	-	51.0	76.0	30.30	6.25	12.0	M8 × 12	10.0	8.5	8.5	36,390	36,430	0.58	
QEH35CA							50	83.0	108.0	21.30							51,180	59,280	0.90	

EGW/QEW

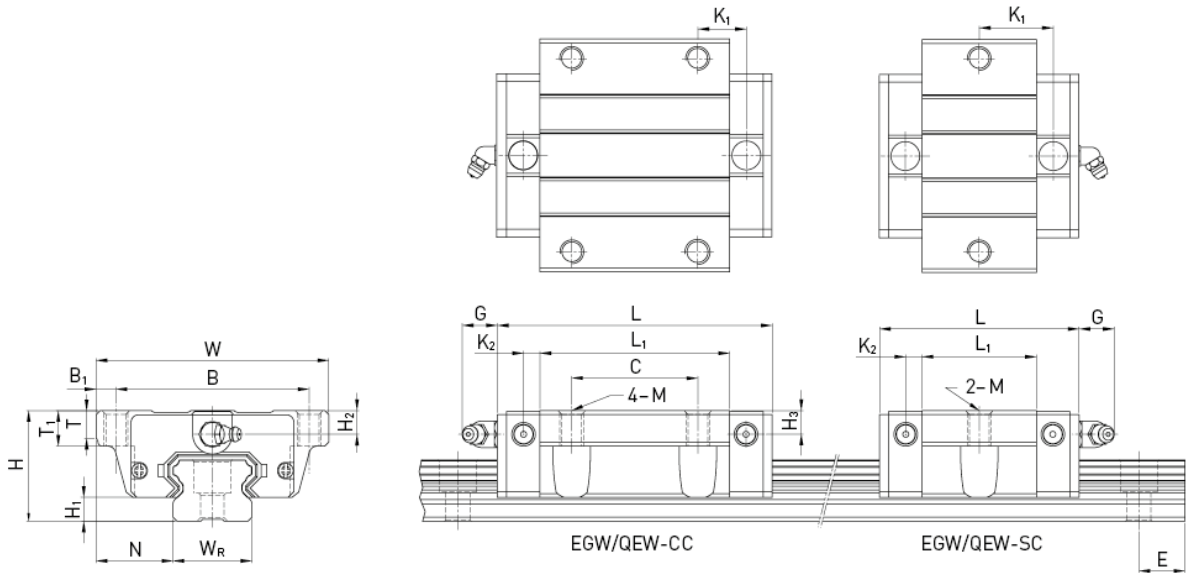

Dimensions of the block																					
Series/ Size	Installation dimensions [mm]			Dimensions of the block [mm]														Load ratings [N]		Weight (kg)	
	H	H ₁	N	W	B	B ₁	C	L ₁	L	K ₁	K ₂	G	M	T	T ₁	H ₂	H ₃	C _{dyn}	C ₀		
EGW15SC	24	4.5	18.5	52	41	5.5	-	23.1	40.1	14.80	3.50	5.7	M5	5.0	7	5.5	6.0	5,350	9,400	0.12	
EGW15CC							26	39.8	56.8	10.15								7,830	16,190	0.21	
QEW15SC	24	4.0	18.5	52	41	5.5	-	23.1	40.1	14.80	3.50	5.7	M5	5.0	-	5.5	6.0	8,560	8,790	0.12	
QEW15CC							26	39.8	56.8	10.15								12,530	15,280	0.21	
EGW20SC	28	6.0	19.5	59	49	5.0	-	29.0	50.0	18.75	4.15	12.0	M6	7.0	9	6.0	6.0	7,230	12,740	0.19	
EGW20CC							32	48.1	69.1	12.30								10,310	21,130	0.32	
QEW20SC	28	6.0	19.5	59	49	5.0	-	29.0	50.0	18.75	4.15	12.0	M6	7.0	-	6.0	6.5	11,570	12,180	0.19	
QEW20CC							32	48.1	69.1	12.30								16,500	20,210	0.31	
EGW25SC	33	7.0	25.0	73	60	6.5	-	35.5	59.1	21.90	4.55	12.0	M8	7.5	10	8.0	8.0	11,400	19,500	0.35	
EGW25CC							35	59.0	82.6	16.15								16,270	32,400	0.59	
QEW25SC	33	6.2	25.0	73	60	6.5	-	35.5	60.1	21.90	5.00	12.0	M8	7.5	-	8.0	8.0	18,240	18,900	0.34	
QEW25CC							35	59.0	83.6	16.15								26,030	31,490	0.58	
EGW30SC	42	10.0	31.0	90	72	9.0	-	41.5	69.5	26.75	6.00	12.0	M10	7.0	10	8.0	9.0	16,420	28,100	0.62	
EGW30CC							40	70.1	98.1	21.05								23,700	47,460	1.04	
QEW30SC	42	10.0	31.0	90	72	9.0	-	41.5	67.5	25.75	6.00	12.0	M10	7.0	-	8.0	9.0	26,270	27,820	0.61	
QEW30CC							40	70.1	96.1	20.05								37,920	46,630	1.03	
EGW35SC	48	11.0	33.0	100	82	9.0	-	45.0	75.0	28.50	7.00	12.0	M10	10.0	13	8.5	8.5	22,660	37,380	0.91	
EGW35CC							50	78.0	108.0	20.00								33,350	64,840	1.40	
QEW35SC	48	11.0	33.0	100	82	9.0	-	51.0	76.0	30.30	6.25	12.0	M10	10.0	13	8.5	8.5	36,390	36,430	0.77	
QEW35CC							50	83.0	108.0	21.30								51,180	59,280	1.19	

12.3.4 Dimensions of the WE/QW blocks

WEH/QWH

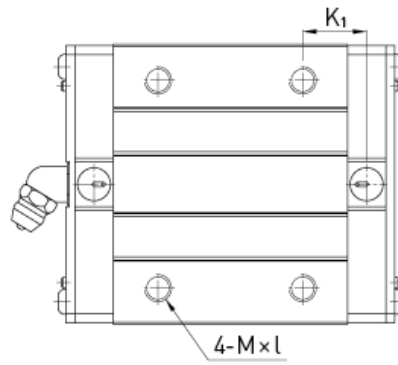

WE_17
WE/QW_21

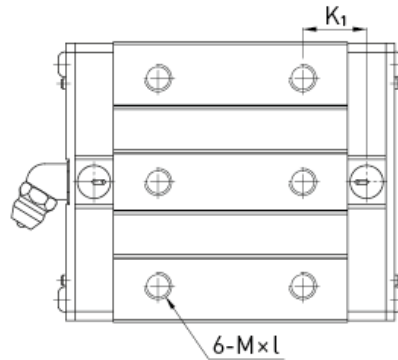

WE/QW_27
WE/QW_35
WE_50

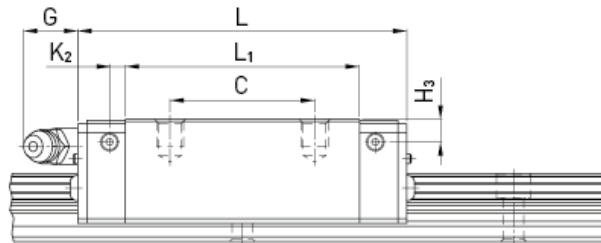
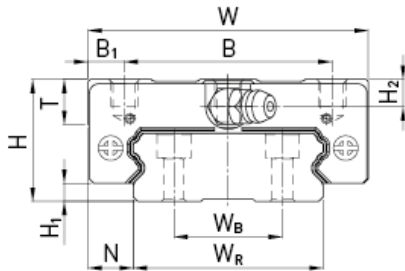

Dimensions of the block																				
Series/ Size	Installation dimensions [mm]			Dimensions of the block [mm]													Load ratings [N]		Weight (kg)	
	H	H ₁	N	W	B	B ₁	C	L ₁	L	K ₁	K ₂	G	M × l	T	H ₂	H ₃	C _{dyn}	C ₀		
WEH17CA	17	2.5	8.5	50	29	10.5	15	35.0	50.6	-	3.10	4.9	M4 × 5	6.0	4.0	3.0	5,230	9,640	0.12	
WEH21CA	21	3.0	8.5	54	31	11.5	19	41.7	59.0	14.68	3.65	12.0	M5 × 6	8.0	4.5	4.2	7,210	13,700	0.20	
QWH21CA	21	3.0	8.5	54	31	11.5	19	41.7	59.0	14.68	3.65	12.0	M5 × 6	8.0	4.5	4.2	9,000	12,100	0.20	
WEH27CA	27	4.0	10.0	62	46	8.0	32	51.8	72.8	14.15	3.50	12.0	M6 × 6	10.0	6.0	5.0	12,400	21,600	0.35	
QWH27CA	27	4.0	10.0	62	46	8.0	32	56.6	73.2	15.45	3.15	12.0	M6 × 6	10.0	6.0	5.0	16,000	22,200	0.35	
WEH35CA	35	4.0	15.5	100	76	12.0	50	77.6	102.6	18.35	5.25	12.0	M8 × 8	13.0	8.0	6.5	29,800	49,400	1.10	
QWH35CA	35	4.0	15.5	100	76	12.0	50	83.0	107.0	21.50	5.50	12.0	M8 × 8	13.0	8.0	6.5	36,800	49,200	1.10	
WEH50CA	50	7.5	20.0	130	100	15.0	65	112.0	140.0	28.05	6.00	12.9	M10 × 15	19.5	12.0	10.5	61,520	97,000	3.16	

WEW

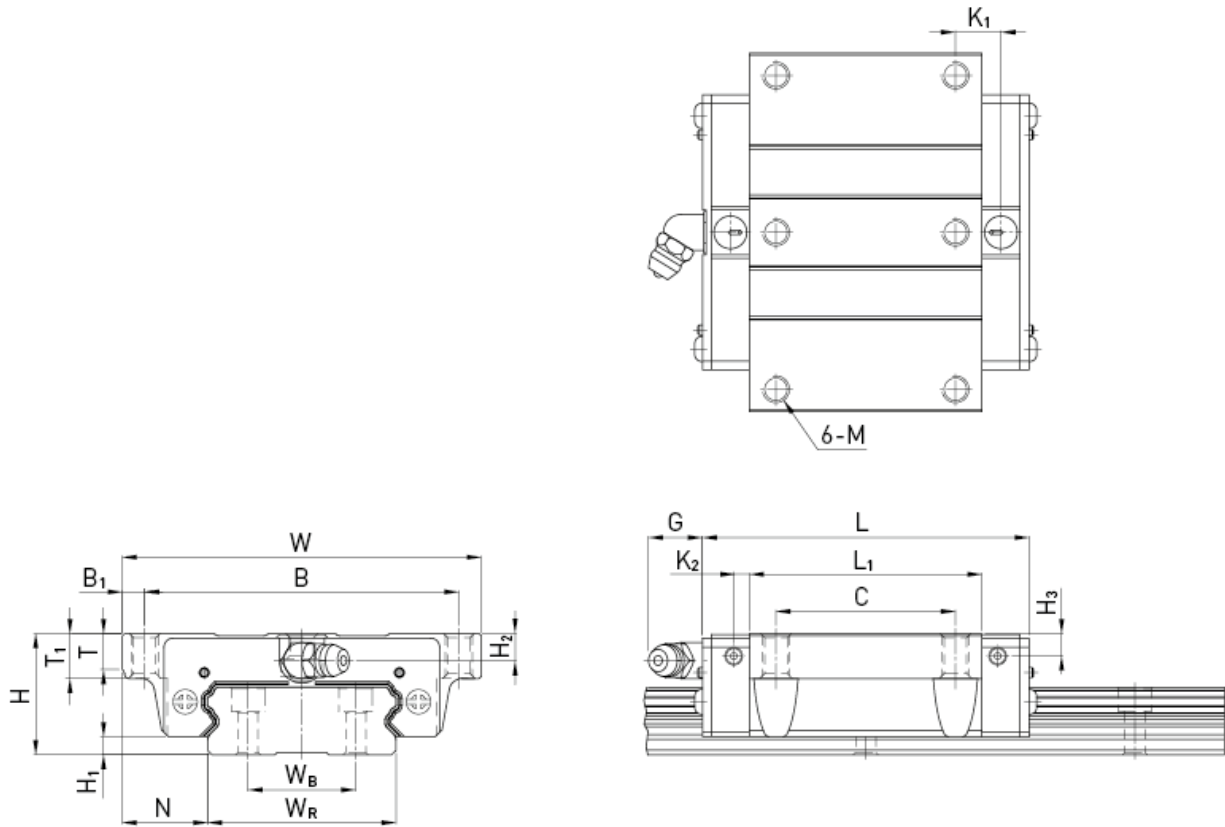

Dimensions of the block																						
Series/ Size	Installation dimensions [mm]			Dimensions of the block [mm]															Load ratings [N]		Weight (kg)	
	H	H ₁	N	W	B	B ₁	C	L ₁	L	K ₁	K ₂	G	M	T	T ₁	H ₂	H ₃	C _{dyn}	C ₀			
WEW17CC	17	2.5	13.5	60	53	3.5	26	35.0	50.6	-	3.10	4.9	M4	5.3	6	4.0	3.0	5,230	9,640	0.13		
WEW21CC	21	3.0	15.5	68	60	4.0	29	41.7	59.0	9.68	3.65	12.0	M5	7.3	8	4.5	4.2	7,210	13,700	0.23		
QWW21CC	21	3.0	15.5	68	60	4.0	29	41.7	59.0	9.68	3.65	12.0	M5	7.3	8	4.5	4.2	9,000	12,100	0.23		
WEW27CC	27	4.0	19.0	80	70	5.0	40	51.8	72.8	10.15	3.50	12.0	M6	8.0	10	6.0	5.0	12,400	21,600	0.43		
QWW27CC	27	4.0	19.0	80	70	5.0	40	56.6	73.2	15.45	3.15	12.0	M6	8.0	10	6.0	5.0	16,000	22,200	0.43		
WEW35CC	35	4.0	25.5	120	107	6.5	60	77.6	102.6	13.35	5.25	12.0	M8	11.2	14	8.0	6.5	29,800	49,400	1.26		
QWW35CC	35	4.0	25.5	120	107	6.5	60	83.0	107.0	21.50	5.50	12.0	M8	11.2	14	8.0	6.5	36,800	49,200	1.26		
WEW50CC	50	7.5	36.0	162	144	9.0	80	112.0	140.0	20.55	6.00	12.9	M10	14.0	18	12.0	10.5	61,520	97,000	3.71		

12.3.5 Dimensions of the MG blocks

MGN

MGN02, MGN03

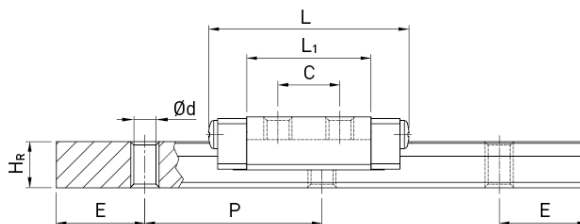
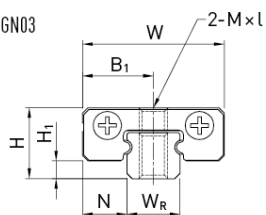

MGN05

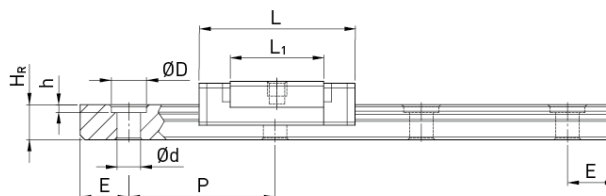
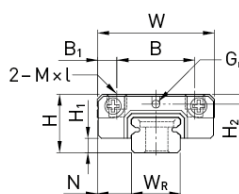

MGN07, MGN09, MGN12

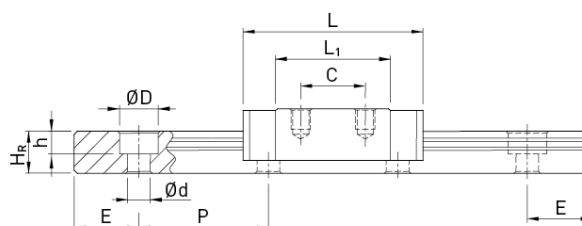
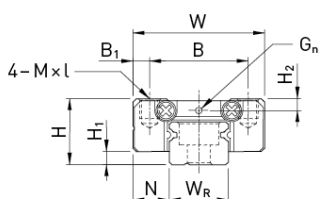

MGN15

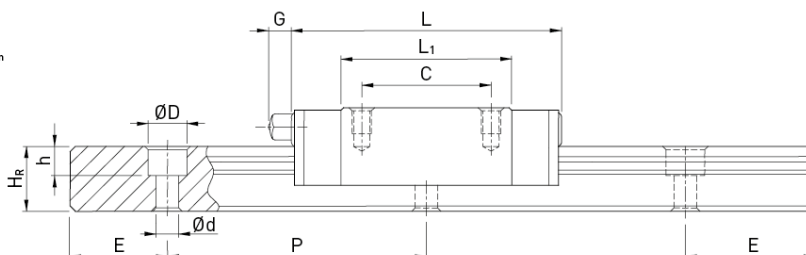
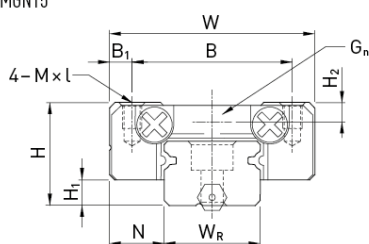

Dimensions of the block																	
Series/ Size	Installation dimensions [mm]			Dimensions of the block [mm]										Load ratings [N]		Weight (kg)	
	H	H ₁	N	W	B	B ₁	C	L ₁	L	G	G _n	M × l	H ₂	C _{dyn}	C ₀		
MGN02C	3.2	0.7	2.0	6	-	3	4.0	9.4	12.5	-	-	M1,4	-	220	400	0.001	
MGN03C	4.0	1.0	2.5	8	-	4	3.5	7.0	11.3	-	-	M1,6	-	290	440	0.001	
MGN03H							5.5	11.0	15.3			M2		390	680	0.002	
MGN05C	6.0	1.5	3.5	12	8	2.0	-	9.6	16.0	-	Ø 0.8	M2 × 1.5	1.0	540	840	0.008	
MGN05H							-	12.6	19.0	-				670	1,080	0.010	
MGN07C	8.0	1.5	5.0	17	12	2.5	8	13.5	22.5	-	Ø 1.2	M2 × 2.5	1.5	980	1,245	0.010	
MGN07H							13	21.8	30.8					1,372	1,960	0.020	
MGN09C	10.0	2.0	5.5	20	15	2.5	10	18.9	28.9	-	Ø 1.4	M3 × 3	1.8	1,860	2,550	0.020	
MGN09H							16	29.9	39.9					2,550	4,020	0.030	
MGN12C	13.0	3.0	7.5	27	20	3.5	15	21.7	34.7	-	Ø 2	M3 × 3.5	2.5	2,840	3,920	0.030	
MGN12H							20	32.4	45.4					3,720	5,880	0.050	
MGN15C	16.0	4.0	8.5	32	25	3.5	20	26.7	42.1	4.5	M3	M3 × 4	3.0	4,610	5,590	0.060	
MGN15H							25	43.4	58.8					6,370	9,110	0.090	

The size MG02 and MG03 blocks are only available mounted on the profile rail.

MGW

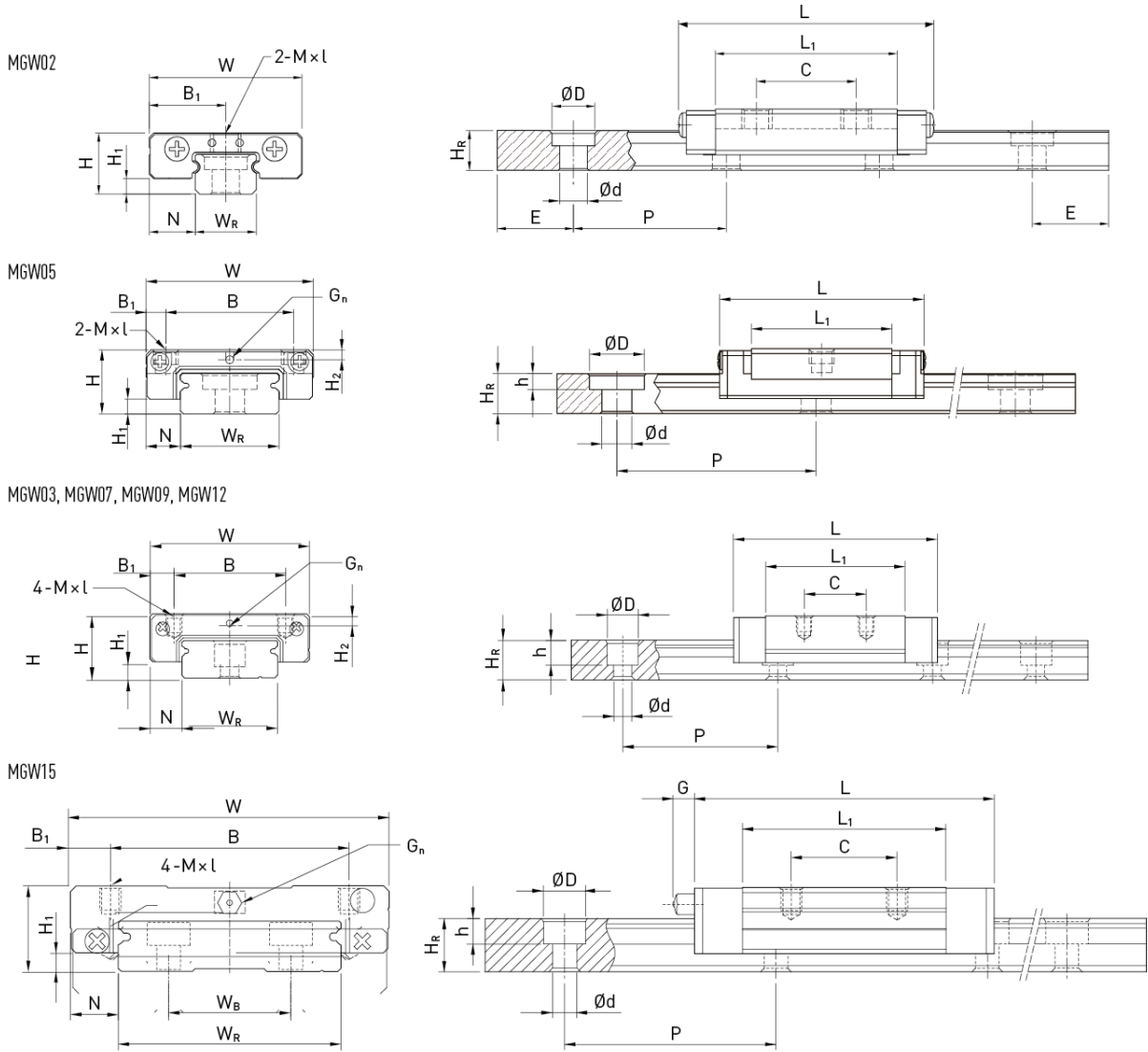

Dimensions of the block																
Series/ Size	Installation dimensions [mm]			Dimensions of the block [mm]										Load ratings [N]		Weight (kg)
	H	H ₁	N	W	B	B ₁	C	L ₁	L	G	G _n	M × l	H ₂	C _{dyn}	C ₀	
MGW02C	4.0	1.0	3.0	10	-	5.0	6.5	11.9	16.7	-	-	M2	-	410	730	0.002
MGW03C	4.5	1.0	3.0	12	-	6.0	4.5	9.6	15.0	-	Ø 0.5	M2	0.65	540	840	0.003
MGW03H							8.0	14.2	19.6					680	1,180	0.004
MGW05C	6.5	1.5	3.5	17	13	2.0	-	14.1	20.5	-	Ø 0.8	M2,5 × 1.5	1.00	680	1,180	0.02
MGW07C	9.0	1.9	5.5	25	19	3.0	10	21.0	31.2	-	Ø 1.2	M3 × 3	1.85	1,370	2,060	0.02
MGW07H							19	30.8	41.0					1,770	3,140	0.03
MGW09C	12.0	2.9	6.0	30	21	4.5	12	27.5	39.3	-	Ø 1.4	M3 × 3	2.40	2,750	4,120	0.04
MGW09H					23	3.5	24	38.5	50.7					3,430	5,890	0.06
MGW12C	14.0	3.4	8.0	40	28	6.0	15	31.3	46.1	-	Ø 2	M3 × 3.6	2.80	3,920	5,590	0.07
MGW12H							28	45.6	60.4					5,100	8,240	0.10
MGW15C	16.0	3.4	9.0	60	45	7.5	20	38.0	54.8	5.2	M3	M4 × 4.2	3.20	6,770	9,220	0.14
MGW15H							35	57.0	73.8					8,930	13,380	0.22

The size MG02 and MG03 blocks are only available mounted on the profile rail.

12.3.6 Dimensions of the RG/QR blocks

RGH/QRH

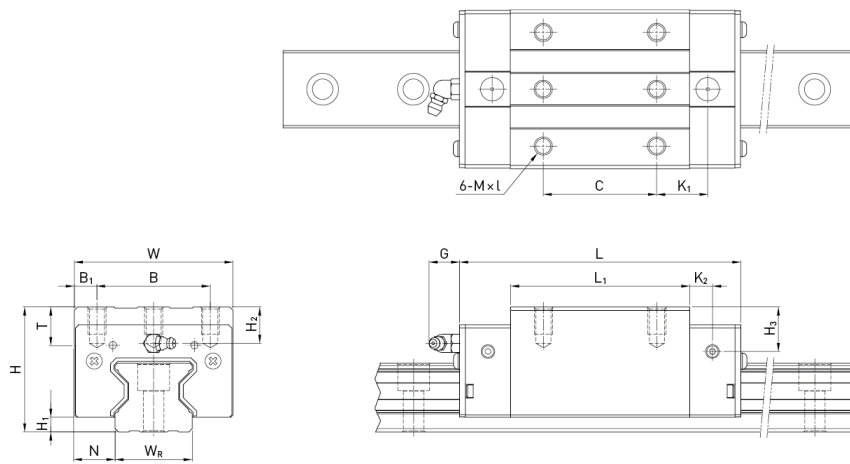

Dimensions of the block

Series/ Size	Installation dimensions [mm]			Dimensions of the block [mm]													Load ratings [N]		Weight (kg)
	H	H ₁	N	W	B	B ₁	C	L ₁	L	K ₁	K ₂	G	M × L	T	H ₂	H ₃	C _{dyn}	C ₀	
RGH15CA	28	4.0	9.5	34	26	4.0	26	45.0	68.0	13.40	4.70	5.3	M4 × 8	6.0	7.6	10.1	11,300	24,000	0.20
RGH20CA	34	5.0	12.0	44	32	6.0	36	57.5	86.0	15.80	6.00	5.3	M5 × 8	8.0	8.3	8.3	21,300	46,700	0.40
RGH20HA								50	77.5	106.0	18.80						26,900	63,000	0.53
RGH25CA	40	5.5	12.5	48	35	6.5	35	64.5	97.9	20.75	7.25	12.0	M6 × 8	9.5	10.2	10.0	27,700	57,100	0.61
RGH25HA								50	81.0	114.4	21.50						33,900	73,400	0.75
QRH25CA	40	5.5	12.5	48	35	6.5	35	66.0	97.9	20.75	7.25	12.0	M6 × 8	9.5	10.2	10.0	38,500	54,400	0.60
QRH25HA								50	81.0	112.9	21.50						44,700	65,300	0.74
RGH30CA	45	6.0	16.0	60	40	10.0	40	71.0	109.8	23.50	8.00	12.0	M8 × 10	9.5	9.5	10.3	39,100	82,100	0.90
RGH30HA								60	93.0	131.8	24.50						48,100	105,000	1.16
QRH30CA	45	6.0	16.0	60	40	10.0	40	71.0	109.8	23.50	8.00	12.0	M8 × 10	9.5	9.5	10.3	51,500	73,000	0.89
QRH30HA								60	93.0	131.8	24.50						64,700	95,800	1.15
RGH35CA	55	6.5	18.0	70	50	10.0	50	79.0	124.0	22.50	10.00	12.0	M8 × 12	12.0	16.0	19.6	57,900	105,200	1.57
RGH35HA								72	106.5	151.5	25.25						73,100	142,000	2.06
QRH35CA	55	6.5	18.0	70	50	10.0	50	79.0	124.0	22.50	10.00	12.0	M8 × 12	12.0	16.0	19.6	77,000	94,700	1.56
QRH35HA								72	106.5	151.5	25.25						95,700	126,300	2.04
RGH45CA	70	8.0	20.5	86	60	13.0	60	106.0	153.2	31.00	10.00	12.9	M10 × 17	16.0	20.0	24.0	92,600	178,800	3.18
RGH45HA								80	139.8	187.0	37.90						116,000	230,900	4.13
QRH45CA	70	8.0	20.5	86	60	13.0	60	106.0	153.2	31.00	10.00	12.9	M10 × 17	16.0	20.0	24.0	123,200	156,400	3.16
QRH45HA								80	139.8	187.0	37.90						150,800	208,600	4.10
RGH55CA	80	10.0	23.5	100	75	12.5	75	125.5	183.7	37.75	12.50	12.9	M12 × 18	17.5	22.0	27.5	130,500	252,000	4.89
RGH55HA								95	173.8	232.0	51.90						167,800	348,000	6.68
RGH65CA	90	12.0	31.5	126	76	25.0	70	160.0	232.0	60.80	15.80	12.9	M16 × 20	25.0	15.0	15.0	213,000	411,600	8.89
RGH65HA								120	223.0	295.0	67.30						275,300	572,700	12.13

RGW/QRW

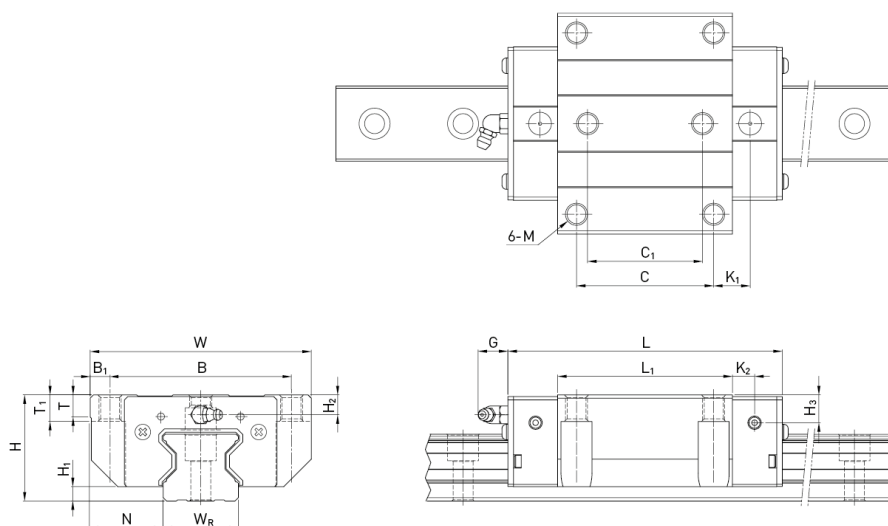

Dimensions of the block																						
Series/ Size	Installation dimensions [mm]			Dimensions of the block [mm]															Load ratings [N]		Weight (kg)	
	H	H ₁	N	W	B	B ₁	C	C ₁	L ₁	L	K ₁	K ₂	G	M	T	T ₁	H ₂	H ₃	C _{dyn}	C ₀		
RGW15CC	24	4.0	16.0	47	38	4.5	30	26	45.0	68.0	11.40	4.70	5.3	M5	6.0	7	3.6	6.1	11,300	24,000	0.22	
RGW20CC	30	5.0	21.5	63	53	5.0	40	35	57.5	86.0	13.80	6.00	5.3	M6	8.0	10	4.3	4.3	21,300	46,700	0.47	
RGW20HC									77.5	106.0	23.80								26,900	63,000	0.63	
RGW25CC	36	5.5	23.5	70	57	6.5	45	40	64.5	97.9	15.75	7.25	12.0	M8	9.5	10	6.2	6.0	27,700	57,100	0.72	
RGW25HC									81.0	114.4	24.00								33,900	73,400	0.91	
QRW25CC	36	5.5	23.5	70	57	6.5	45	40	66.0	97.9	15.75	7.25	12.0	M8	9.5	10	6.2	6.0	38,500	54,400	0.71	
QRW25HC									81.0	112.9	24.00								44,700	65,300	0.90	
RGW30CC	42	6.0	31.0	90	72	9.0	52	44	71.0	109.8	17.50	8.00	12.0	M10	9.5	10	6.5	7.3	39,100	82,100	1.16	
RGW30HC									93.0	131.8	28.50								48,100	105,000	1.52	
QRW30CC	42	6.0	31.0	90	72	9.0	52	44	71.0	109.8	17.50	8.00	12.0	M10	9.5	10	6.5	7.3	51,500	73,000	1.15	
QRW30HC									93.0	131.8	28.50								64,700	95,800	1.51	
RGW35CC	48	6.5	33.0	100	82	9.0	62	52	79.0	124.0	16.50	10.00	12.0	M10	12.0	13	9.0	12.6	57,900	105,200	1.75	
RGW35HC									106.5	151.5	30.25								73,100	142,000	2.40	
QRW35CC	48	6.5	33.0	100	82	9.0	62	52	79.0	124.0	16.50	10.00	12.0	M10	12.0	13	9.0	12.6	77,000	94,700	1.74	
QRW35HC									106.5	151.5	30.25								95,700	126,300	2.38	
RGW45CC	60	8.0	37.5	120	100	10.0	80	60	106.0	153.2	21.00	10.00	12.9	M12	14.0	15	10.0	14.0	92,600	178,800	3.43	
RGW45HC									139.8	183.0	37.90								116,000	230,900	4.57	
QRW45CC	60	8.0	37.5	120	100	10.0	80	60	106.0	153.2	21.00	10.00	12.9	M12	14.0	15	10.0	14.0	123,200	156,400	3.41	
QRW45HC									139.8	183.0	37.90								150,800	208,600	4.54	
RGW55CC	70	10.0	43.5	140	116	12.0	95	70	125.5	183.7	27.75	12.50	12.9	M14	16.0	17	12.0	17.5	130,500	252,000	5.43	
RGW55HC									173.8	232.0	51.90								167,800	348,000	7.61	
RGW65CC	90	12.0	53.5	170	142	14.0	110	82	160.0	232.0	40.80	15.80	12.9	M16	22.0	23	15.0	15.0	213,000	411,600	11.63	
RGW65HC									223.0	295.0	72.30								275,300	572,700	16.58	

12.3.7 Dimensions of the CRG blocks

CRGH

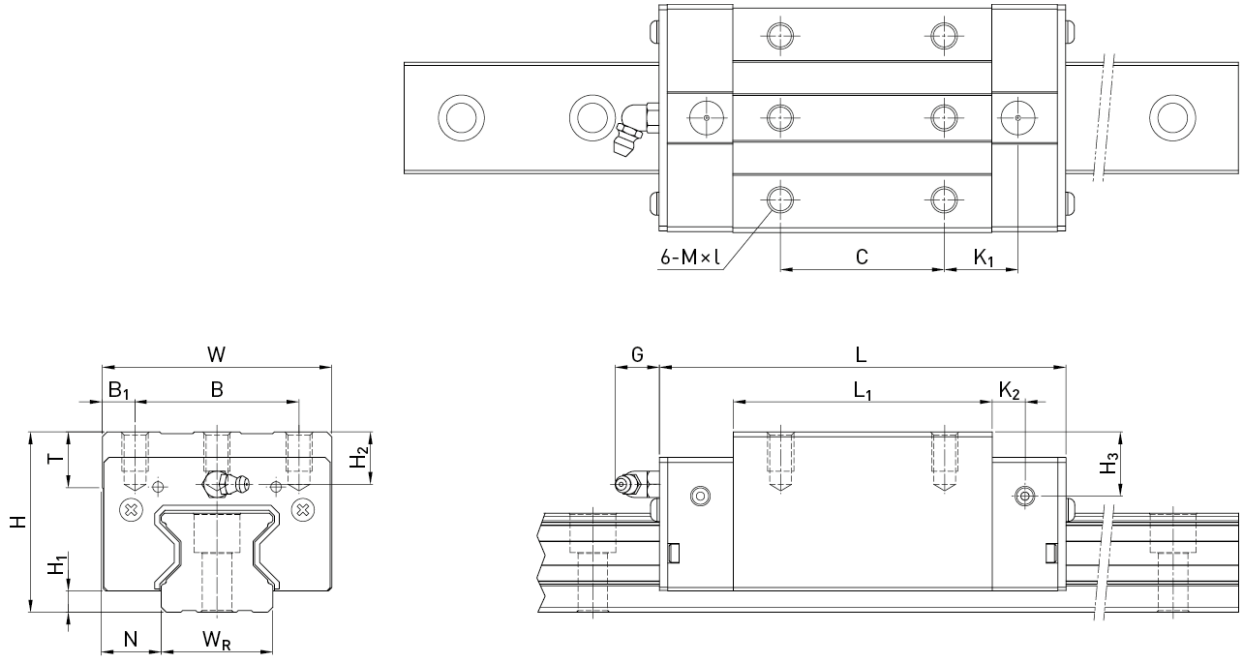

Dimensions of the block

Series/ Size	Installation dimensions [mm]			Dimensions of the block [mm]													Load ratings [N]		Weight (kg)
	H	H ₁	N	W	B	B ₁	C	L ₁	L	K ₁	K ₂	G	M x l	T	H ₂	H ₃	C _{dyn}	C ₀	
CRGH15CA	28	4.0	9.5	34	26	4.0	26	45.0	68.0	13.40	4.70	5.3	M4 x 8	6.0	7.6	10.1	11,300	24,000	0.20
CRGH20CA	34	5.0	12.0	44	32	6.0	36	57.5	86.0	15.80	6.00	5.3	M5 x 8	8.0	8.3	8.3	21,300	46,700	0.40
CRGH20HA							50	77.5	106.0	18.80	26,900	63,000					0.53		
CRGH25CA	40	5.5	12.5	48	35	6.5	35	64.5	97.9	20.75	7.25	12.0	M6 x 8	9.5	10.2	10.0	27,700	57,100	0.61
CRGH25HA							50	81.0	114.4	21.50	33,900	73,400					0.75		
CRGH30CA	45	6.0	16.0	60	40	10.0	40	71.0	109.8	23.50	8.00	12.0	M8 x 10	9.5	9.5	10.3	39,100	82,100	0.90
CRGH30HA							60	93.0	131.8	24.50	48,100	105,000					1.16		
CRGH35CA	55	6.5	18.0	70	50	10.0	50	73.0	124.0	22.50	10.00	12.0	M8 x 12	12.0	16.0	19.6	57,900	105,200	1.57
CRGH35HA							72	106.5	151.5	25.25	73,100	142,000					2.06		
CRGH45CA	70	8.0	20.5	86	60	13.0	60	106.0	153.2	31.00	10.00	12.9	M10 x 17	16.0	20.0	24.0	92,600	178,800	3.18
CRGH45HA							80	139.8	187.0	37.90	116,000	230,900					4.13		
CRGH55CA	80	10.0	23.5	100	75	12.5	75	125.5	183.7	37.75	12.50	12.9	M12 x 18	17.5	22.0	27.5	130,500	252,000	4.89
CRGH55HA							95	173.8	232.0	51.90	167,800	348,000					6.68		
CRGH65CA	90	12.0	31.5	126	76	25.0	70	160.0	232.0	60.80	15.80	12.9	M16 x 20	25.0	15.0	15.0	213,000	411,600	8.89
CRGH65HA							120	223.0	295.0	67.30	275,300	572,700					12.13		

CRGW

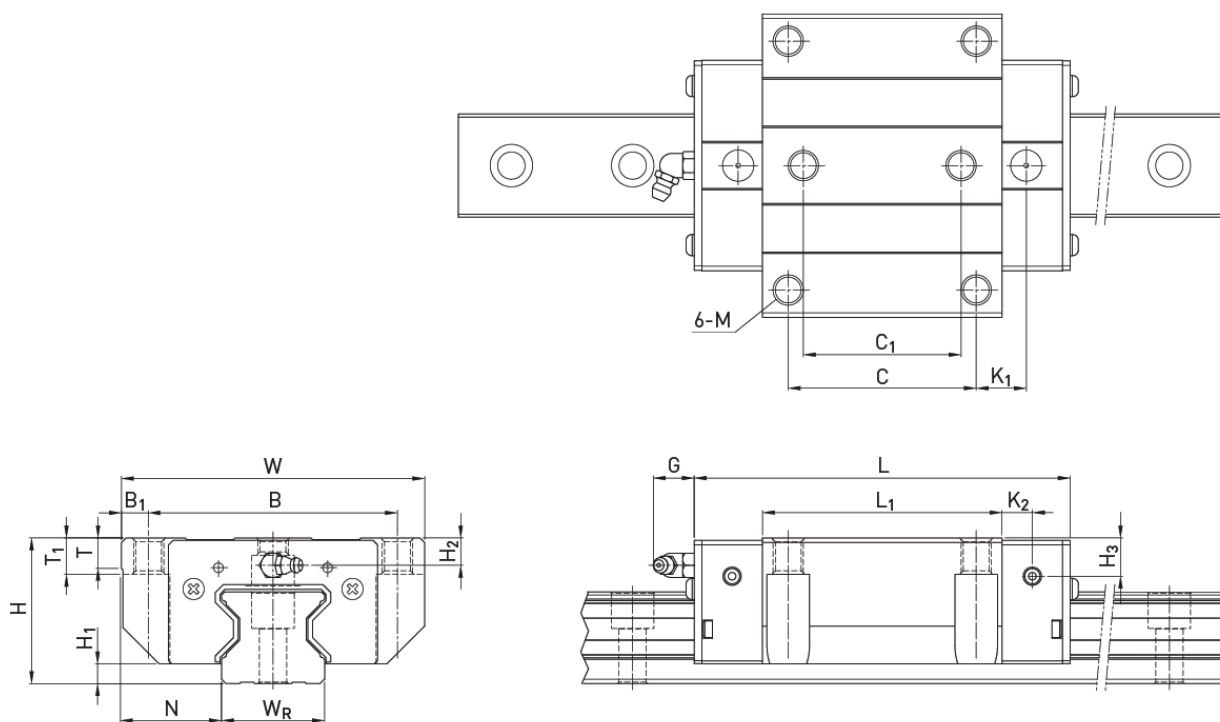

Dimensions of the block

Series/ Size	Installation dimensions [mm]		Dimensions of the block [mm]																Load ratings [N]		Weight (kg)
	H	H ₁	N	W	B	B ₁	C	C ₁	L ₁	L	K ₁	K ₂	G	M	T	T ₁	H ₂	H ₃	C _{dyn}	C ₀	
CRGW15CC	24	4.0	16.0	47	38	4.5	30	26	45.0	68.0	11.40	4.70	5.3	M5	6.0	6.95	3.6	6.1	11,300	24,000	0.22
CRGW20CC	30	5.0	21.5	63	53	5.0	40	35	57.5	86.0	13.80	6.00	5.3	M6	8.0	10.00	4.3	4.3	21,300	46,700	0.47
CRGW20HC									77.5												106.0
CRGW25CC	36	5.5	23.5	70	57	6.5	45	40	64.5	97.9	15.75	7.25	12.0	M8	9.5	10.00	6.2	6.0	27,700	57,100	0.72
CRGW25HC									81.0												114.4
CRGW30CC	42	6.0	31.0	90	72	9.0	52	44	71.0	109.8	17.50	8.00	12.0	M10	9.5	10.00	6.5	7.3	39,100	82,100	1.16
CRGW30HC									93.0												131.8
CRGW35CC	48	6.5	33.0	100	82	9.0	62	52	79.0	124.0	16.50	10.00	12.0	M10	12.0	13.00	9.0	12.6	57,900	105,200	1.75
CRGW35HC									106.5												151.5
CRGW45CC	60	8.0	37.5	120	100	10.0	80	60	106.0	153.2	21.00	10.00	12.9	M12	14.0	15.00	10.0	14.0	92,600	178,800	3.43
CRGW45HC									139.8												187.0
CRGW55CC	70	10.0	43.5	140	116	12.0	95	70	125.5	183.7	27.75	12.50	12.9	M14	16.0	17.00	12.0	17.5	130,500	252,000	5.43
CRGW55HC									173.8												232.0
CRGW65CC	90	12.0	53.5	170	142	14.0	110	82	160.0	232.0	40.80	15.80	12.9	M16	22.0	23.00	15.0	15.0	213,000	411,600	11.63
CRGW65HC									223.0												295.0

12.4 Technical data of profile rails

12.4.1 Dimensions of profile rails HG

Profile rail HG is used for both blocks HG and QH.

HGR_R

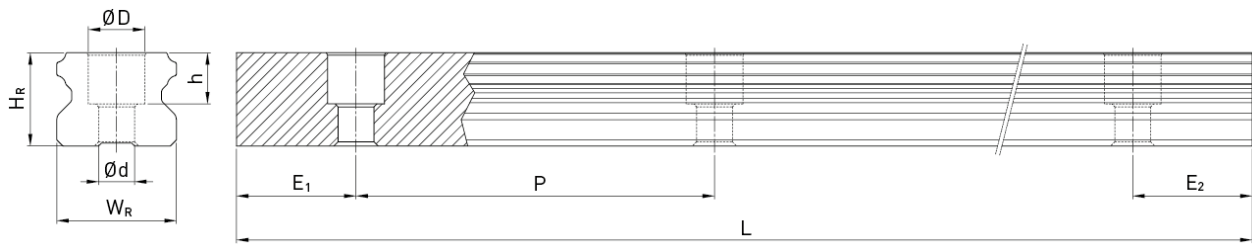

Dimensions of profile rail HGR_R

Series/ Size	Mounting bolt for rail [mm]	Dimensions of the profile rail [mm]						Max. length (mm)	Max. length $E_1=E_2$ (mm)	Min. length (mm)	$E_{1/2}$ min (mm)	$E_{1/2}$ max (mm)	Weight (kg/m)
		W_R	H_R	D	H	d	P						
HGR15R	M4 × 20	15	15.0	7.5	5.3	4.5	60	4,000	3,900	132	6	54	1.45
HGR20R	M5 × 20	20	17.5	9.5	8.5	6.0	60	4,000/5,600 ¹⁾	3,900/5,520 ¹⁾	134	7	53	2.21
HGR25R	M6 × 25	23	22.0	11.0	9.0	7.0	60	4,000/5,600 ¹⁾	3,900/5,520 ¹⁾	136	8	52	3.21
HGR30R	M8 × 30	28	26.0	14.0	12.0	9.0	80	4,000/5,600 ¹⁾	3,900/5,520 ¹⁾	178	9	71	4.47
HGR35R	M8 × 35	34	29.0	14.0	12.0	9.0	80	4,000/5,600 ¹⁾	3,900/5,520 ¹⁾	178	9	71	6.30
HGR45R	M12 × 45	45	38.0	20.0	17.0	14.0	105	4,000/5,600 ¹⁾	3,885/5,460 ¹⁾	234	12	93	10.41
HGR55R	M14 × 55	53	44.0	23.0	20.0	16.0	120	4,000/5,600 ¹⁾	3,840/5,440 ¹⁾	268	14	106	15.08
HGR65R	M16 × 65	63	53.0	26.0	22.0	18.0	150	4,000/5,600 ¹⁾	3,750/5,350 ¹⁾	330	15	135	21.18

¹⁾ Optional type on request

HGR_T

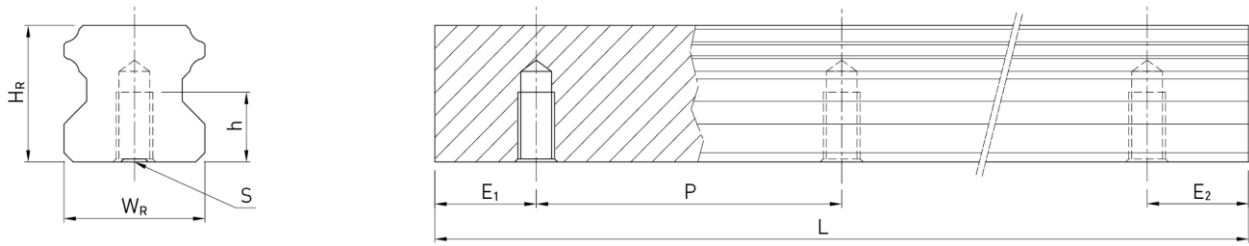

Dimensions of profile rail HGR_T

Series/ Size	Dimensions of the profile rail [mm]					Max. length (mm)	Max. length E ₁ =E ₂ (mm)	Min. length (mm)	E _{1/2} min (mm)	E _{1/2} max (mm)	Weight (kg/m)
	W _R	H _R	S	H	P						
HGR15T	15	15.0	M5	8	60	4,000	3,900	132	6	54	1.48
HGR20T	20	17.5	M6	10	60	4,000	3,900	134	7	53	2.29
HGR25T	23	22.0	M6	12	60	4,000	3,900	136	8	52	3.35
HGR30T	28	26.0	M8	15	80	4,000	3,920	178	9	71	4.67
HGR35T	34	29.0	M8	17	80	4,000	3,920	178	9	71	6.51
HGR45T	45	38.0	M12	24	105	4,000	3,885	234	12	93	10.87
HGR55T	53	44.0	M14	24	120	4,000	3,840	268	14	106	15.67
HGR65T	63	53.0	M20 ¹⁾	30	150	4,000	3,750	330	15	135	21.73

¹⁾ Deviates from DIN 645

Note:

1. The tolerance for E is +0.5 to -1 mm for standard rails, for joint connections 0 to -0.3 mm.
2. If no information is provided on the E_{1/2} dimensions, the maximum number of mounting holes is determined taking into account E_{1/2} min.
3. The profile rails are shortened to the desired length. If no information on the E_{1/2} dimensions is provided, then the rails are manufactured symmetrically.

CGR_R

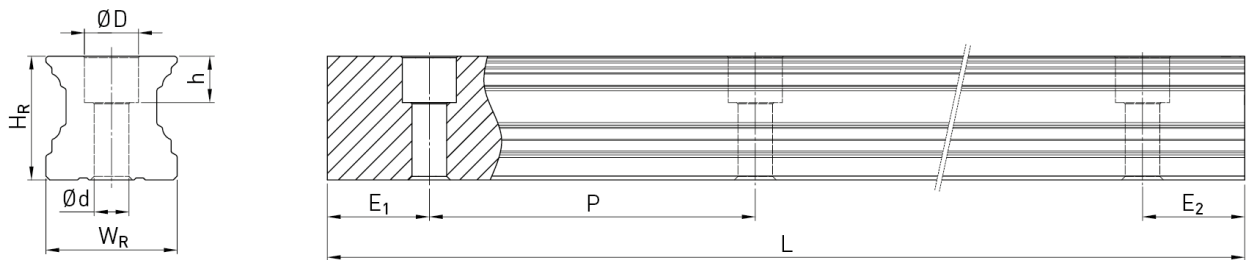

Dimensions of profile rail CGR_R

Series/ Size	Assembly screw for rail [mm]	Dimensions of the profile rail [mm]						Max. length (mm)	Max. length E ₁ =E ₂ (mm)	Min. length (mm)	E _{1/2} min (mm) ¹⁾	E _{1/2} min (mm) ²⁾	E _{1/2} max (mm)	Weight (kg/m)
		W _R	H _R	D	H	d	P							
CGR15R	M4 × 20	15	16.20	7.5	5.9	4.5	60	4,000	3,900	72	6	9	54	1.58
CGR20R	M5 × 25	20	20.55	9.5	8.5	6.0	60	4,000	3,900	74	7	10	53	2.48
CGR25R	M6 × 30	23	24.25	11.0	9.0	7.0	60	4,000	3,900	76	8	11	52	3.38
CGR30R	M8 × 35	28	28.35	14.0	12.4	9.0	80	4,000	3,920	98	9	12	71	5.10
CGR35R	M8 × 40	34	31.85	14.0	12.0	9.0	80	4,000	3,920	98	9	16	71	7.14
CGR45R	M12 × 50	45	39.85	20.0	17.0	14.0	105	4,000	3,885	129	12	19	93	11.51

¹⁾ E_{1/2} min without cover strip and with cover strip (clamp: steel clamp)

²⁾ E_{1/2} min with cover strip (clamp: front clamping bolt)

CGR_T

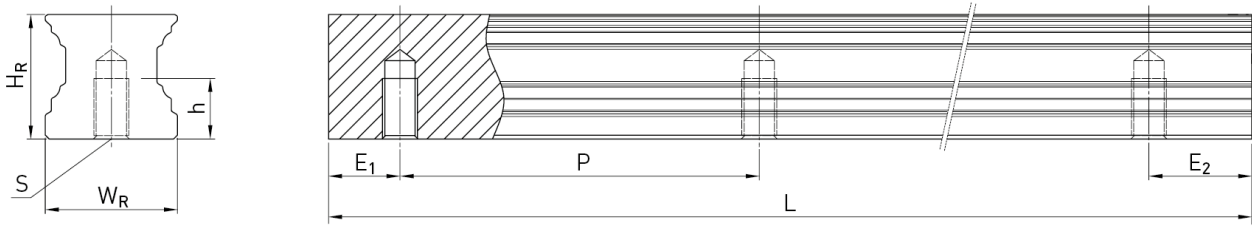

Dimensions of profile rail CGR_T

Series/ Size	Dimensions of the profile rail [mm]					Max. length (mm)	Max. length $E_1=E_2$ (mm)	Min. length (mm)	$E_{1/2}$ min (mm) ¹⁾	$E_{1/2}$ min (mm) ²⁾	$E_{1/2}$ max (mm)	Weight (kg/m)
	W_R	H_R	S	H	P							
CGR15T	15	16.20	M5	8	60	4,000	3,900	72	6	9	54	1.58
CGR20T	20	20.55	M6	10	60	4,000	3,900	74	7	10	53	2.48
CGR25T	23	24.25	M6	12	60	4,000	3,900	76	8	11	52	3.38
CGR30T	28	28.35	M8	15	80	4,000	3,920	98	9	12	71	5.10
CGR35T	34	31.85	M8	17	80	4,000	3,920	98	9	16	71	7.14
CGR45T	45	39.85	M12	24	105	4,000	3,885	129	12	19	93	11.51

¹⁾ $E_{1/2}$ min without cover strip and with cover strip (clamp: steel clamp)

²⁾ $E_{1/2}$ min with cover strip (clamp: front clamping bolt)

Note:

1. The tolerance for E is +0.5 to -1 mm for standard rails, for joint connections 0 to -0.3 mm.
2. If no information is provided on the $E_{1/2}$ dimensions, the maximum number of mounting holes is determined taking into account $E_{1/2}$ min.
3. The profile rails are shortened to the desired length. If no information on the $E_{1/2}$ dimensions is provided, then the rails are manufactured symmetrically.

12.4.2 Dimensions of profile rails EG

The EG profile rail is used for both the EG and QE blocks.

EGR_R

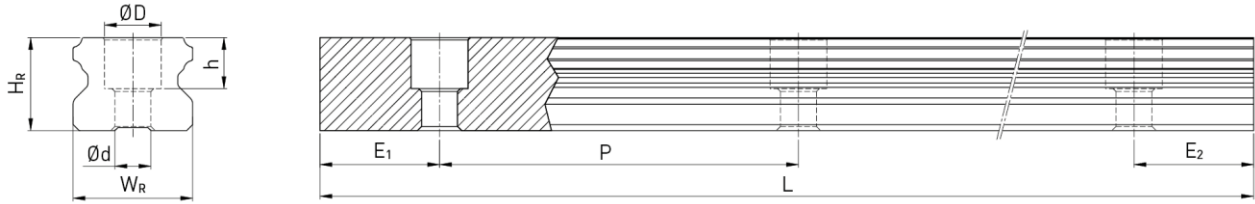

Dimensions of profile rail EGR_R

Series/ Size	Assembly screw for rail [mm]	Dimensions of the profile rail [mm]						Max. length (mm)	Max. length E ₁ =E ₂ (mm)	Min. length (mm)	E _{1/2} min (mm)	E _{1/2} max (mm)	Weight (kg/m)
		W _R	H _R	D	H	d	P						
EGR15R	M3 × 16	15	12.5	6.0	4.5	3.5	60	4,000	3,900	132	6	54	1.25
EGR20R	M5 × 20	20	15.5	9.5	8.5	6.0	60	4,000	3,900	134	7	53	2.08
EGR25R	M6 × 25	23	18.0	11.0	9.0	7.0	60	4,000	3,900	136	8	52	2.67
EGR30R	M6 × 30	28	23.0	11.0	9.0	7.0	80	4,000	3,920	178	9	71	4.35
EGR35R	M8 × 35	34	27.5	14.0	12.0	9.0	80	4,000	3,920	178	9	71	6.14

EGR_U

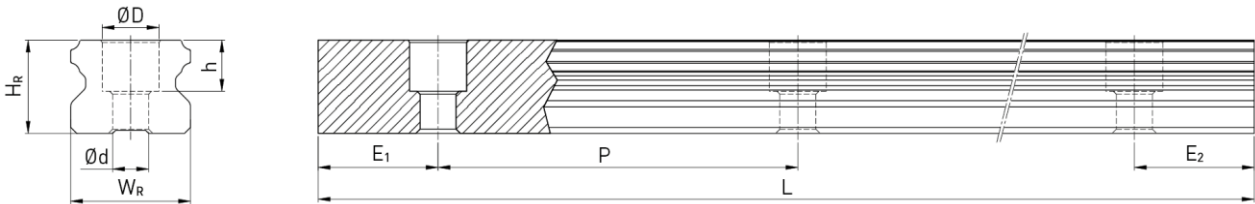

Dimensions of profile rail EGR_U

Series/ Size	Assembly screw for rail [mm]	Dimensions of the profile rail [mm]						Max. length (mm)	Max. length E ₁ =E ₂ (mm)	Min. length (mm)	E _{1/2} min (mm)	E _{1/2} max (mm)	Weight (kg/m)
		W _R	H _R	D	H	d	P						
EGR15U	M4 × 16	15	12.5	6.0	4.5	3.5	60	4,000	3,900	132	6	54	1.25
EGR30U	M8 × 30	28	23.0	12.0	14.0	9.0	80	4,000	3,920	178	9	71	4.23

Note:

1. The tolerance for E is +0.5 to -1 mm for standard rails, for joint connections 0 to -0.3 mm.
2. If no information is provided on the E_{1/2} dimensions, the maximum number of mounting holes is determined taking into account E_{1/2} min.
3. The profile rails are shortened to the desired length. If no information on the E_{1/2} dimensions is provided, then the rails are manufactured symmetrically.

EGR_T

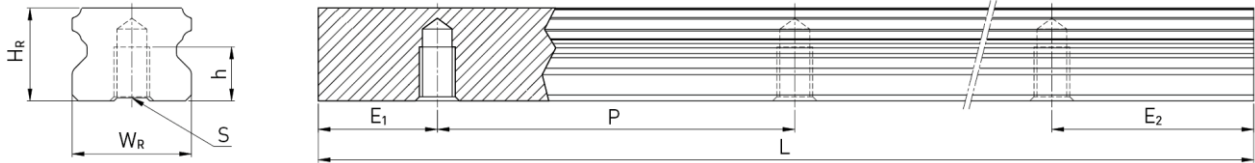

Dimensions of profile rail EGR_T											
Series/ Size	Dimensions of the profile rail [mm]					Max. length (mm)	Max. length $E_1=E_2$ (mm)	Min. length (mm)	$E_{1/2}$ min (mm)	$E_{1/2}$ max (mm)	Weight (kg/m)
	W_R	H_R	S	H	P						
EGR15T	15	12.5	M5	7	60	4,000	3,900	132	6	54	1.26
EGR20T	20	15.5	M6	9	60	4,000	3,900	134	7	53	2.15
EGR25T	23	18.0	M6	10	60	4,000	3,900	136	8	52	2.79
EGR30T	28	23.0	M8	14	80	4,000	3,920	178	9	71	4.42
EGR35T	34	27.5	M8	17	80	4,000	3,920	178	9	71	6.34

Note:

1. The tolerance for E is +0.5 to -1 mm for standard rails, for joint connections 0 to -0.3 mm.
2. If no information is provided on the $E_{1/2}$ dimensions, the maximum number of mounting holes is determined taking into account $E_{1/2}$ min.
3. The profile rails are shortened to the desired length. If no information on the $E_{1/2}$ dimensions is provided, then the rails are manufactured symmetrically.

12.4.3 Dimensions of profile rails WE

WER_R

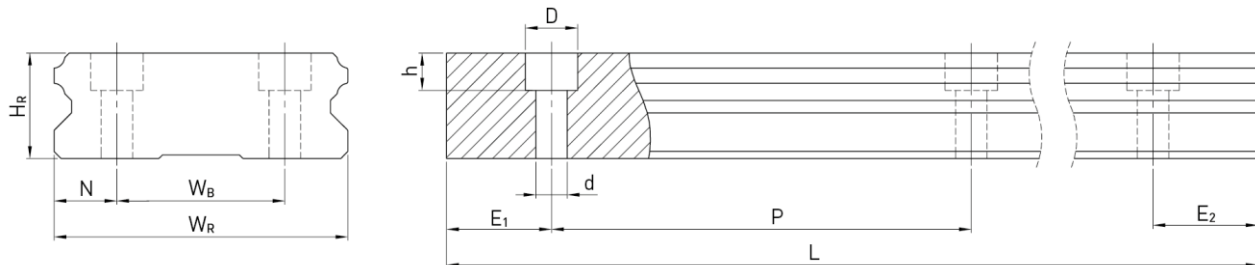

Dimensions of profile rail WER_R														
Series/ Size	Assembly screw for rail [mm]	Dimensions of the profile rail [mm]							Max. length (mm)	Max. length $E_1=E_2$ (mm)	Min. length (mm)	$E_{1/2}$ min (mm)	$E_{1/2}$ max (mm)	Weight (kg/m)
		W_R	W_B	H_R	D	H	d	P						
WER17R	M4 × 12	33	18	9.3	7.5	5.3	4.5	40	4,000	3,960	92	6	34	2.2
WER21R	M4 × 16	37	22	11.0	7.5	5.3	4.5	50	4,000	3,950	112	6	44	3.0
WER27R	M4 × 20	42	24	15.0	7.5	5.3	4.5	60	4,000	3,900	132	6	54	4.7
WER35R	M6 × 25	69	40	19.0	11.0	9.0	7.0	80	4,000	3,920	176	8	72	9.7
WER50R	M8 × 30	90	60	24.0	14.0	12.0	9.0	80	4,000	3,920	178	9	71	14.6

WER_T

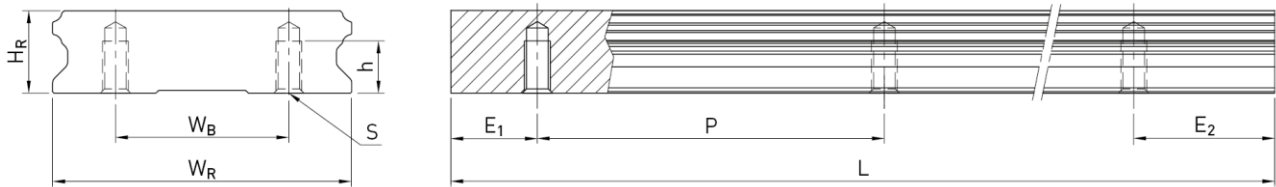

Dimensions of profile rail WER_T

Series/ Size	Dimensions of the profile rail [mm]						Max. length (mm)	Max. length E ₁ =E ₂ (mm)	Min. length (mm)	E _{1/2} min (mm)	E _{1/2} max (mm)	Weight (kg/m)
	W _R	W _B	H _R	S	H	P						
WER21T	37	22	11	M4	7.0	50	4,000	3,950	112	6	44	3.0
WER27T	42	24	15	M5	7.5	60	4,000	3,900	132	6	54	4.7
WER35T	69	40	19	M6	12.0	80	4,000	3,920	176	8	72	9.7

Note:

1. The tolerance for E is +0.5 to -1 mm for standard rails, for joint connections 0 to -0.3 mm.
2. If no information is provided on the E_{1/2} dimensions, the maximum number of mounting holes is determined taking into account E_{1/2} min.
3. The profile rails are shortened to the desired length. If no information on the E_{1/2} dimensions is provided, then the rails are manufactured symmetrically.

12.4.4 Dimensions of profile rails MG

MGN_R

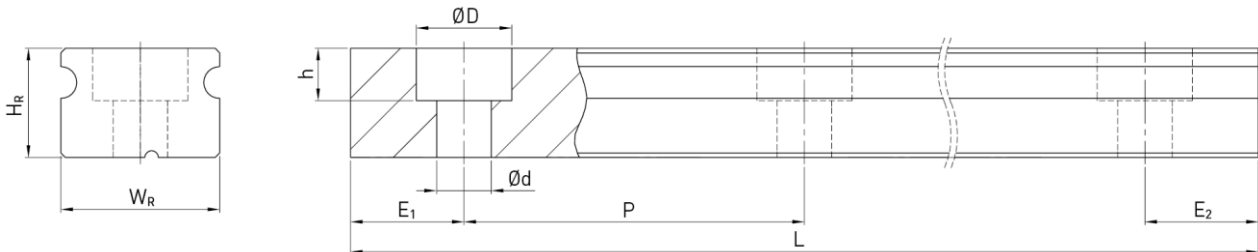

Dimensions of profile rail MGN_R

Series/ Size	Assembly screw for rail [mm]	Dimensions of the profile rail [mm]						Max. length (mm)	Max. length E ₁ =E ₂ (mm)	Min. length (mm)	E _{1/2} min (mm)	E _{1/2} max (mm)	Weight (kg/m)
		W _R	H _R	D	H	d	P						
MGNR02R	M1	2	2	M1			8	250	240	12	2	6	0.03
MGNR03R	M1,6	3	2.6	M1,6			10	250	240	14	2	8	0.05
MGNR05R	M2 × 6 ¹⁾	5	3.6	3.6	0.8	2.4	15	250	225	23	4	11	0.15
MGNR07R	M2 × 8	7	4.8	4.2	2.3	2.4	15	600	585	25	5	12	0.22
MGNR09R	M3 × 10	9	6.5	6.0	3.5	3.5	20	1,200	1,180	30	5	15	0.38
MGNR12R	M3 × 10	12	8.0	6.0	4.5	3.5	25	2,000	1,975	35	5	20	0.65
MGNR15R	M3 × 12	15	10.0	6.0	4.5	3.5	40	2,000	1,960	52	6	34	1.06

¹⁾ Special screw (Art.No. 20-000004)

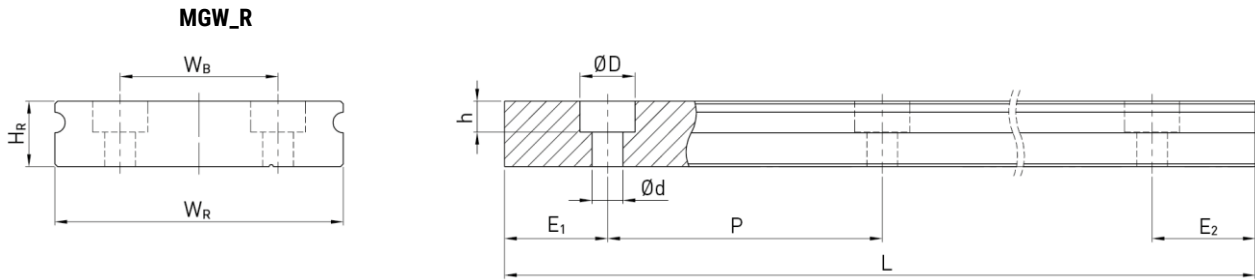

Dimensions of profile rail MGW_R														
Series/ Size	Assembly screw for rail [mm]	Dimensions of the profile rail [mm]							Max. length (mm)	Max. length $E_1=E_2$ (mm)	Min. length (mm)	$E_{1/2}$ min (mm)	$E_{1/2}$ max (mm)	Weight (kg/m)
		W_R	H_R	W_B	D	H	d	P						
MGWR02R	M1.6 ³⁾	4	2.6	-	2.8	1.0	1.8	10	250	240	16	3	7	0.70
MGWR03R	M2	6	2.9	-	3.6	1.5	2.4	15	250	225	23	4	11	0.13
MGWR05R	M2.5 × 7 ²⁾	10	4.0	-	5.5	1.6	3.0	20	250	220	30	5	11	0.34
MGWR07R	M3 × 8	14	5.2	-	6.0	3.2	3.5	30	600	570	40	5	24	0.51
MGWR09R	M3 × 10	18	7.0	-	6.0	4.5	3.5	30	2,000	1,950	40	5	24	0.91
MGWR12R	M4 × 12	24	8.5	-	8.0	4.5	4.5	40	2,000	1,960	52	6	32	1.49
MGWR15R	M4 × 16	42	9.5	23	8.0	4.5	4.5	40	2,000	1,960	52	6	32	2.86

²⁾ Special screw (art.no. 20-00174 1)

³⁾ Special screw

Note:

1. The tolerance for E is +0.5 to -1 mm for standard rails and 0 to -0.3 mm for joint connections.
2. If no information is provided on the $E_{1/2}$ dimensions, the maximum number of mounting holes is determined taking into account $E_{1/2}$ min.
3. The profile rails are shortened to the desired length. If no information on the $E_{1/2}$ dimensions is provided, then the rails are manufactured symmetrically.

12.4.5 Dimensions of profile rails RG

The RG profile rail is used for both the RG and QR blocks.

RGR_R

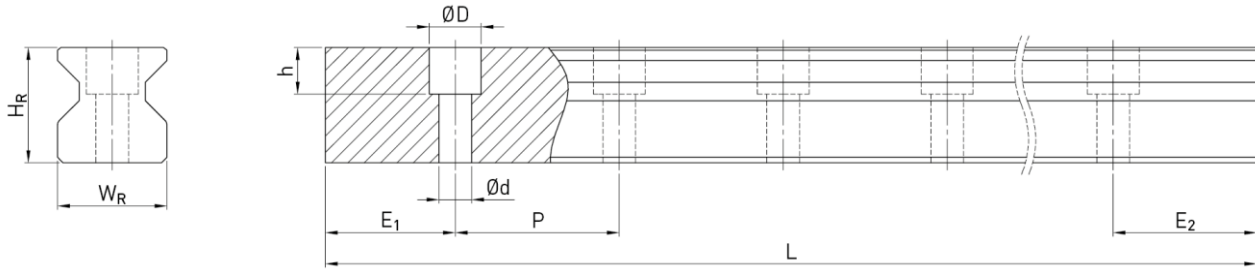

Dimensions of profile rail RGR_R													
Series/ Size	Mounting bolt for rail [mm]	Dimensions of the profile rail [mm]						Max. length (mm)	Max. length E ₁ =E ₂ (mm)	Min. length h (mm)	E _{1/2} min (mm)	E _{1/2} max (mm)	Weight (kg/m)
		W _R	H _R	D	H	d	P						
RGR15R	M4 × 20	15	16.5	7.5	5.7	4.5	30.0	4,000	3,960.0	72	6	24.0	1.70
RGR20R	M5 × 25	20	21.0	9.5	8.5	6.0	30.0	4,000	3,960.0	74	7	23.0	2.66
RGR25R	M6 × 30	23	23.6	11.0	9.0	7.0	30.0	4,000	3,960.0	76	8	22.0	3.08
RGR30R	M8 × 35	28	28.0	14.0	12.0	9.0	40.0	4,000	3,920.0	98	9	31.0	4.41
RGR35R	M8 × 35	34	30.2	14.0	12.0	9.0	40.0	4,000	3,920.0	98	9	31.0	6.06
RGR45R	M12 × 45	45	38.0	20.0	17.0	14.0	52.5	4,000/5,600 ¹⁾	3,937.5/5,437.5 ¹⁾	129	12	40.5	9.97
RGR55R	M14 × 55	53	44.0	23.0	20.0	16.0	60.0	4,000/5,600 ¹⁾	3,900.0/5,500 ¹⁾	148	14	46.0	13.98
RGR65R	M16 × 65	63	53.0	26.0	22.0	18.0	75.0	4,000/5,600 ¹⁾	3,900.0/5,500 ¹⁾	180	15	60.0	20.22

¹⁾ Optional type on request

RGR_T

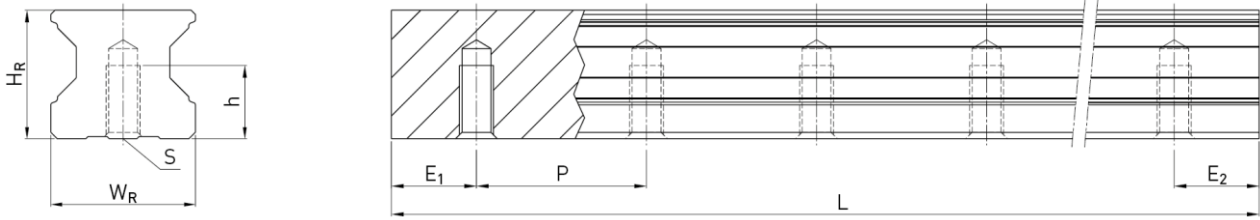

Dimensions of profile rail RGR_T

Series/ Size	Dimensions of the profile rail [mm]					Max. length (mm)	Max. length $E_1=E_2$ (mm)	Min. length (mm)	$E_{1/2}$ min (mm)	$E_{1/2}$ max (mm)	Weight (kg/m)
	W_R	H_R	S	H	P						
RGR15T	15	16.5	M5	8.0	30.0	4,000	3,960.0	72	6	24.0	1.86
RGR20T	20	21.0	M6	10.0	30.0	4,000	3,960.0	74	7	23.0	2.76
RGR25T	23	23.6	M6	12.0	30.0	4,000	3,960.0	76	8	22.0	3.36
RGR30T	28	28.0	M8	15.0	40.0	4,000	3,920.0	98	9	31.0	4.82
RGR35T	34	30.2	M8	17.0	40.0	4,000	3,920.0	98	9	31.0	6.48
RGR45T	45	38.0	M12	24.0	52.5	4,000	3,937.5	129	12	40.5	10.83
RGR55T	53	44.0	M14	24.0	60.0	4,000	3,900.0	148	14	46.0	15.15
RGR65T	63	53.0	M20 ¹⁾	30.0	75.0	4,000	3,900.0	180	15	60.0	21.24

¹⁾ Deviates from DIN 645

Note:

1. The tolerance for E is +0.5 to -1 mm for standard rails, for joint connections 0 to -0.3 mm.
2. If no information is provided on the $E_{1/2}$ dimensions, the maximum number of mounting holes is determined taking into account $E_{1/2}$ min.
3. The profile rails are shortened to the desired length. If no information on the $E_{1/2}$ dimensions is provided, then the rails are manufactured symmetrically.

CRGR_R

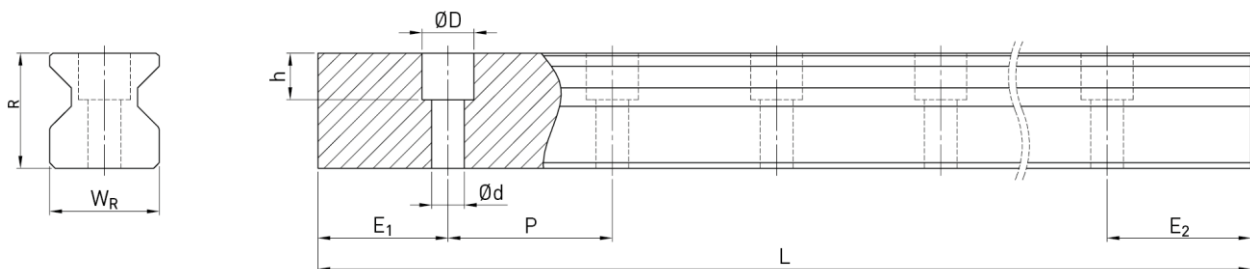

Dimensions of profile rail CRGR_R

Series/ Size	Assembly screw for rail [mm]	Dimensions of the profile rail [mm]						Max. length (mm)	Max. length $E_1=E_2$ (mm)	Min. length (mm)	$E_{1/2}$ min (mm)	$E_{1/2}$ max (mm)	Weight (kg/m)
		W_R	H_R	D	H	d	P						
CRGR15R	M4 × 20	15	16.5	7.5	5.7	4.5	30.0	4,000	3,960	72	6	24.0	1.70
CRGR20R	M5 × 25	20	21.0	9.5	8.5	6.0	30.0	4,000	3,960	74	7	23.0	2.66
CRGR25R	M6 × 30	23	23.6	11.0	9.0	7.0	30.0	4,000	3,960	76	8	22.0	3.08
CRGR30R	M8 × 35	28	28.0	14.0	12.0	9.0	40.0	4,000	3,920	98	9	31.0	4.41
CRGR35R	M8 × 35	34	30.2	14.0	12.0	9.0	40.0	4,000	3,920	98	9	31.0	6.06
CRGR45R	M12 × 45	45	38.0	20.0	17.0	14.0	52.5	4,000	3,937.5	129	12	40.5	9.97
CRGR55R	M14 × 55	53	44.0	23.0	20.0	16.0	60.0	4,000	3,900.0	148	14	46.0	13.98
CRGR65R	M16 × 65	63	53.0	26.0	22.0	18.0	75.0	4,000	3,900.0	180	15	60.0	20.22

WE LIVE MOTION

Germany

HIWIN GmbH
Brücklesbünd 1
77654 Offenburg
Deutschland
Fon +49 781 93278-0
info@hiwin.de
hiwin.de

Taiwan

Headquarters
HIWIN Technologies Corp.
No. 7, Jingke Road
Precision Machinery Park
Taichung 40852
Táiwān
Fon +886 4 2359-4510
business@hiwin.tw
hiwin.tw

Taiwan

Headquarters
HIWIN Mikrosystem Corp.
No. 6, Jingke Central Road
Precision Machinery Park
Taichung 40852
Táiwān
Fon +886 4 2355-0110
business@hiwinmikro.tw
hiwinmikro.tw

France

HIWIN SAS
Le Mélèze
17 Rue des Cigognes
67960 Entzheim
France
Fon +33 3 882884-80
contact@hiwin.fr
hiwin.fr

Poland

HIWIN GmbH Biuro Warszawa
ul. Putawska 405a
02-801 Warszawa
Polska
Fon +48 22 46280-00
info@hiwin.pl
hiwin.pl

Denmark

HIWIN GmbH
info@hiwin.dk
hiwin.dk

Netherlands

HIWIN GmbH
info@hiwin.nl
hiwin.nl

Austria

HIWIN GmbH
info@hiwin.at
hiwin.at

Hungary

HIWIN GmbH
info@hiwin.hu
hiwin.hu

Czech Republic

HIWIN s.r.o.
Medkova 888/11
62700 Brno
Česká republika
Fon +42 05 48528-238
info@hiwin.cz
hiwin.cz

Bulgaria

HIWIN Bulgaria
Christopher Columbus No. 4
1582 Sofia
Bulgaria
Fon +35 92 999 52 45
info@hiwin.bg
hiwin.bg

Slovakia

HIWIN s.r.o., o.z.z.o.
Mládežnícka 2101
01701 Považská Bystrica
Slovensko
Fon +421 424 4347-77
info@hiwin.sk
hiwin.sk

Switzerland

HIWIN (Schweiz) GmbH
Eichwiesstrasse 20
8645 Jona
Schweiz
Fon +41 55 22500-25
sales@hiwin.ch
hiwin.ch

Italy

HIWIN Srl
Via Pitagora 4
20861 Brugherio (MB)
Italia
Fon +39 039 28761-68
info@hiwin.it
hiwin.it

Romania

HIWIN Srl
info@hiwin.ro
hiwin.ro

Slovenia

HIWIN Srl
info@hiwin.si
hiwin.si

China

HIWIN Corp.
hiwin.cn

Japan

HIWIN Corp.
info@hiwin.co.jp
hiwin.co.jp

USA

HIWIN Corp.
info@hiwin.com
hiwin.us

Korea

HIWIN Corp.
hiwin.kr

Singapore

HIWIN Corp.
hiwin.sg